

NOVOS 3 INC RS485 Modbus

Room operating unit temperature, optional with humidity | CO2 | VOC

thermokon[®]
HOME OF SENSOR TECHNOLOGY

Datasheet

Subject to technical alteration
Issue date: 05.04.2024 • A140



» APPLICATION

Room control unit for setpoint / fan stage adjustment, presence detection and triggering an ECO mode function. With measurement of the room temperature, optionally with humidity, CO2 or VOC. The setpoint can be changed as needed by turning the encoder within a predefined range, e.g. -3K...+3K. The current status of the setpoint adjustment is visualized by LEDs. By pressing the encoder the ECO-Mode function can be activated. The maintenance-free sensor creates the conditions for a pleasant room climate and well-being. Typical applications are schools, office buildings, hotels or cinemas.

» TYPES AVAILABLE

Room operating unit temperature, optional with humidity, CO2 and VOC – active RS485 Modbus

NOVOS 3 INC



NOVOS 3 INC TD



NOVOS 3 INC FS5



Note: All types also available without symbol (ECO) print available.

» SECURITY ADVICE – CAUTION



The installation and assembly of electrical equipment should only be performed by authorized personnel.

The product should only be used for the intended application. Unauthorised modifications are prohibited! The product must not be used in relation with any equipment that in case of a failure may threaten, directly or indirectly, human health or life or result in danger to human beings, animals or assets. Ensure all power is disconnected before installing. Do not connect to live/operating equipment.

Please comply with

- Local laws, health & safety regulations, technical standards and regulations
- Condition of the device at the time of installation, to ensure safe installation
- This data sheet and installation manual

» MOUNTING ADVISE ROOM SENSORS

The Accuracy of the room sensors are influenced by the technical specifications as well as the positioning and the installation type.

During Assembly:

- Seal mounting box (if present).
- Installation type, air draught, heat source, radiation heat or direct sunlight can affect the measurement.
- Building material specific properties of the installation place (*brick-, concrete-, partition wall, cavity wall, ...*) can affect the measurement.

Assembly not recommendet in...

- Air draught (e.g.: close to windows / doors / fans ...)
- Near heating sources,
- Direct sunlight
- Niches / between furniture / ...

» BUILD-UP OF SELF-HEATING BY ELECTRICAL DISSIPATIVE POWER

Sensors with electronic components always have a dissipative power, which affects the temperature measurement of the ambient air. The dissipation in active temperature sensors shows a linear increase with rising operating voltage. This dissipative power has to be considered when measuring temperature. In case of a fixed operating voltage ($\pm 0,2$ V) this is normally done by adding or reducing a constant offset value.

Thermokon transducers can be operated with variable operating voltages. The transducers are set at the factory with a reference operating voltage of 24 V =.

At this voltage, the expected measuring error of the output signal will be the least. Other operating voltages, can cause a measurement deviation changing power loss of the sensor electronics.

A recalibration can be carried out directly on the unit or via a software variable (app or bus).

Remark: Occurring draught leads to a better carrying-off of dissipative power at the sensor. Thus temporally limited fluctuations might occur upon temperature measurement.

» APPLICATION NOTICE FOR HUMIDITY SENSORS

At regular environmental condition, it is recommended to calibrate the sensor annually to check the compliance with the accuracy required in the application. The following conditions can damage the sensor element or lead in long term to loss of the specified accuracy:

- Mechanical stress
- Contamination (e.g. dust / fingerprints)
- Aggressive chemicals
- Ambient conditions (e.g. condensation on measuring element)



Do not touch the sensor elements!

Re-calibration or exchange of the sensor element are not subject of the general warranty.

» **INFORMATION ABOUT SELF-CALIBRATION FEATURE CO₂**

All gas sensors are subject to drift. The degree of drift is dependent on the use of components and product design. In addition, the following environmental conditions, among others, can accelerate/ favor the aging and wear of the sensors:

- Mechanical stress (also due to temperature fluctuation)
- Contamination (dust / fingerprints e.g.)
- Abrasive chemicals
- Environmental influences (high humidity / condensation on measuring element)

An internal self calibration function with dual channel technology compensates the caused drift. Thermokon sensors are for permanent use (e.g. hospitals).

» **INFORMATION ABOUT INDOOR AIR QUALITY CO₂**

EN 13779 defines several classes for indoor air quality:

Category	CO ₂ content above the content in outdoor air in ppm		Description
	Typical range	Standard value	
IDA1	<400 ppm	350 ppm	Good indoor air quality
IDA2	400.. 600 ppm	500 ppm	Standard indoor air quality
IDA3	600..1.000 ppm	800 ppm	Moderate indoor air quality
IDA4	>1.000 ppm	1.200 ppm	Poor indoor air quality

» **APPLICATION NOTICE FOR AIR QUALITY SENSORS VOC**

Volatile organic compounds (VOC) are gaseous and vaporous substances of organic origin in the air. VOC-sensors monitor the significant part of humanly olfactory sensed air quality. (e.g. body odour | tobacco smoke | odour of materials, furniture, carpets, paint, adhesives, ...)

The VOC-Value is an application-specific indication for air quality and doesn't provide any information about individual components of VOC

A VOC sensor oxidises the organic molecules that collide with it, which results in changing the resistance of the semiconductor.

Any contact with the sensitive sensors must be avoided and will invalidate the warranty.

The VOC Sensor is factory calibrated and can be calibrated via NOVOSapp subsequently, if needed.

» **PRODUCT TESTING AND CERTIFICATION**



Declaration of conformity

The declaration of conformity of the products are available on our website <https://www.thermokon.de/direct/en-gb/categories/novos-3-inc>

» **NOTES ON DISPOSAL**



The crossed-out wheellie bin symbol indicates that the product or removable batteries must not be disposed of with household or commercial waste. Within the EU, you are legally obliged to dispose of the product separately and appropriately in accordance with the national laws of your country. Alternatively, please contact your supplier or Thermokon Sensortechnik GmbH. Further information can be found at: www.thermokon.com

» TECHNICAL DATA

Measuring values <i>(optional)</i>	Temperature (humidity) (CO2) (VOC)
Network technology	RS485 Modbus, RTU, half-duplex, baud rate 9.600, 19.200, 38.400 or 57600, parity: none (1 stopbit, alternative 2 stopbits), even or odd (1 stopbit), Fail-safe Biasing required
Power supply	15..35 V = (or 19..29 V ~)* SELV
Power consumption	typ. 0,4 W (24 V =) 0,8 VA (24 V ~)
Inputs	1x input for floating input
Set point	Rotary/press encoder (Incremental encoder)
Button (T) <i>(optional)</i>	for presence detection, with LED (TD) or fan stage adjustment
LED (D) <i>(optional)</i>	for status feedback, button led color can be set (from 7 colours) via Thermokon NOVOSapp (any from RGB) or BUS
Control functions	INC ECO: temperature- setpoint adjustment, ECO mode INC TD ECO: temperature- setpoint adjustment, presence detection, ECO mode INC FS5 ECO: temperature- setpoint adjustment, fan stage adjustment, ECO mode
Enclosure	PC V0, pure white
Protection	IP20 according to DIN EN 60529
Cable entry	rear entry, breaking points bottom, drill mark top
Connection electrical	tool-free mountable spring terminal, max. 1,5 mm ²
Ambient condition	-4..+158 °F, max. 85% non-condensing, with CO2 or VOC sensor operating temperature range 32..+122 °F
Mounting	surface mounted on flush-mounting box (Ø=2.36 in. 60 mm) or to be mounted flat onto the surface using screws, base part can be mounted and wired separately

» Temperature

Measuring range temperature	-4..+158 °F
Accuracy temperature	±0,5K (typ. at 70 °F)

» Humidity (optional)

Measuring range humidity <i>(optional configurable)</i>	relative humidity (default) 0..100% rH	Enthalpy 0..37 BTU/lb	absolute humidity 0..1,5 0..2,3 g/ft ³	dew point +32..+122 -4..+176 °F
	configurable via Thermokon NOVOSapp or BUS			
Accuracy humidity	±2% between 10..90% rH (typ. at 70 °F)			

» CO2 (optional)

Measuring range CO2	0..2000 ppm 0..5000 ppm (configurable via Thermokon NOVOSapp or BUS)
Accuracy CO2	±50 ppm +3 % of reading (typ. at 70 °F, 50% rH, 1015 hPa)
Calibration	self-calibration dual channel
Sensor	NDIR (non-dispersive, infrared)

» VOC (optional)

Measuring range VOC	0..100 %
Calibration	self-calibration
Sensor	VOC sensor (heated metal oxide semiconductor)

*Power supply

When several BUS devices are supplied by one 24 V AC voltage supply, it is to be ensured that all "positive" operating voltage input terminals (+) of the field devices are connected with each other and all "negative" operating voltage input terminals (-) (=reference potential) are connected together (in-phase connection of field devices).

In case of reversed polarity at one field device, a supply voltage short-circuit would be caused by that device. The consequential short-circuit current flowing through this field may cause damage to it.

Therefore, pay attention to correct wiring.

» MOUNTING ADVICES

Please make sure that the device is de-energized if you want to install it!

The installation can be performed on the flat wall surface or on a flush-mounted box. A representative place should be selected. Sunshine and draft, e.g. in the installation tube should be avoided, so that the measurement result is not falsified. Seal the end of the installation tube.

- For wiring, the upper part of the device must be removed from the base plate. Base plate and upper part are detachably connected to each other by means of locking lugs.
- The mounting of the base plate on the flat wall surface is done with rawplugs and screws.
- Finally, the device is attached to the base plate and fixed with the screw.

Housing open / close

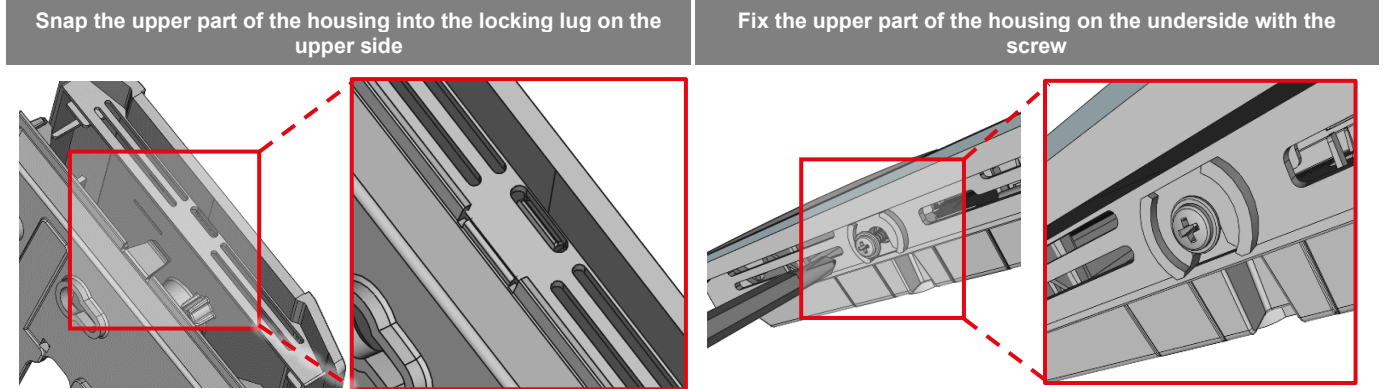

Cable entry

There are predetermined breaking points for 2 optional cable entries on the underside of the base plate. On the upper side of the base plate there are 2 grits as position for a drill hole max. Ø 6 mm | 1/4"

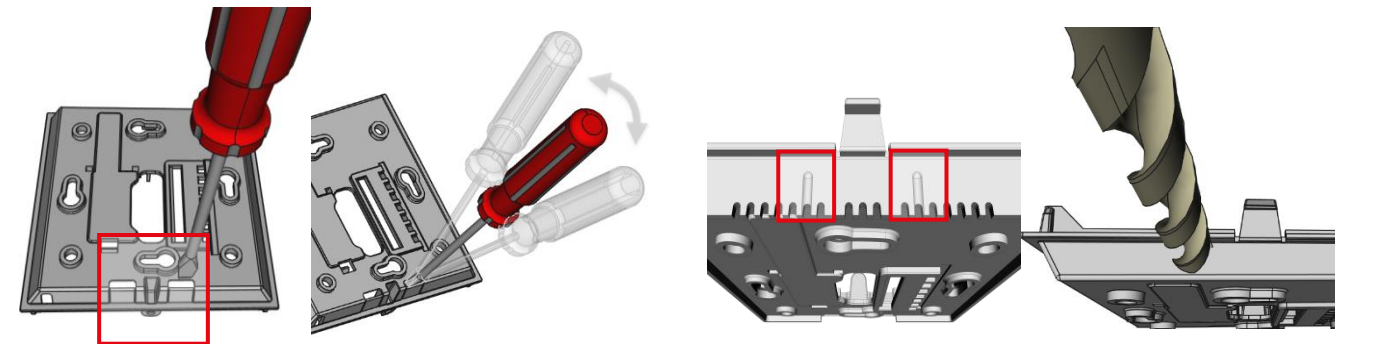

When using a drill, absolutely ensure that the base plate is firmly clamped. Before drilling, the pressure must be reduced and carefully drilled. A sudden break-through of the drill bit can be the result.

» CONNECTION PLAN

Room operating unit – active RS485 Modbus

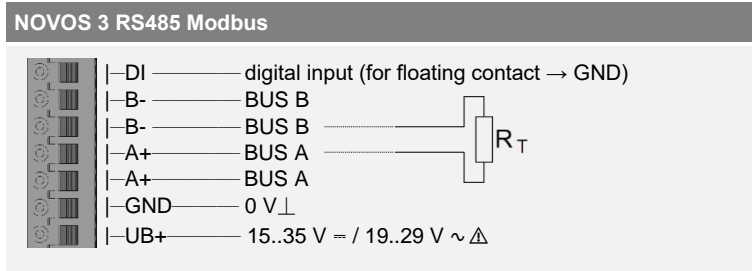



With alternating voltage, the correct polarity must be ensured! Please note the technical data.

Don't forget the BUS termination (120 Ω) at the last device of the line! (Not included in delivery)

» CONFIGURATION

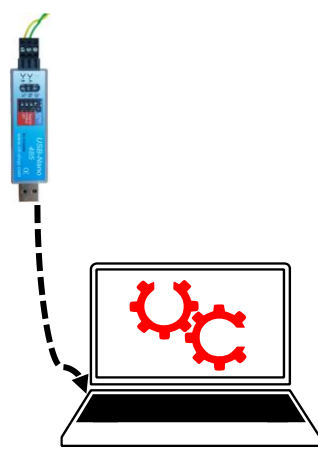
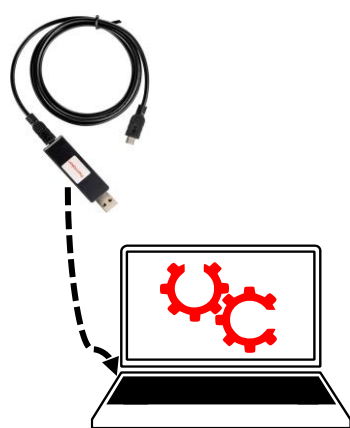
The configuration is performed in powered state. The following options are available for configuring the device:

Device connection	RS485	Micro-USB	Micro-USB
Configuration-adapter	<p>USB-RS485 Converter</p> 	<p>Thermokon USB-Interface</p> 	<p>USB-Bluetooth Dongle</p> 
Configurations-software	<p>PC/Notebook with uConfig software Partly parameterization with Thermokon software uConfig, via USB/RS485 Converter* (Art.-No.: 668293)</p>	<p>PC/Notebook with uConfig software Partly parameterization with Thermokon software uConfig, via Thermokon USB-Interface* (Art.-No.: 597838)</p>	<p>Smartphone/Tablet with NOVOS App Parameterization with mobile device via bluetooth and NOVOSapp. Separately available Bluetooth Dongle* required: (Art.-No.: 668262)</p>

*Commercially available Bluetooth dongles or USB to Micro-USB adapter cables are not compatible. You need a mobile device that supports at least Bluetooth version 4.1. The configuration app with the corresponding instructions can be downloaded from the Google Play Store or the Apple App Store.

Additionally parameterization via building management System (BMS) using the RS485 Modbus network is possible.

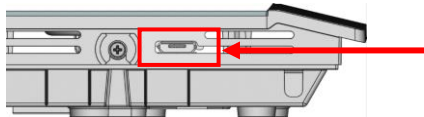

Position of the micro USB port, see bottom of the device, for configuration with Bluetooth dongle or Thermokon USB-Interface

» DIP-SWITCH-SETTINGS

Die Modbus Adresse des Geräts wird über einen 6-fach Dipschalter binärcodiert im Bereich von 1...63 eingestellt. Mit Adresse 0 über DIP ist ein erweiterter Adressbereich (64..247) via NOVOSapp verfügbar.

Modbus-Adress - DIP 1..6 (binary coded)

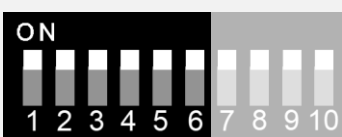
	<table border="1"> <thead> <tr> <th>Dip switch</th> <th>1 = on</th> <th>2 = on</th> <th>3 = on</th> <th>4 = on</th> <th>5 = on</th> <th>6 = on</th> </tr> </thead> <tbody> <tr> <td>Value</td> <td>2⁰ (1)</td> <td>2¹ (2)</td> <td>2² (4)</td> <td>2³ (8)</td> <td>2⁴ (16)</td> <td>2⁵ (32)</td> </tr> </tbody> </table>	Dip switch	1 = on	2 = on	3 = on	4 = on	5 = on	6 = on	Value	2 ⁰ (1)	2 ¹ (2)	2 ² (4)	2 ³ (8)	2 ⁴ (16)	2 ⁵ (32)
Dip switch	1 = on	2 = on	3 = on	4 = on	5 = on	6 = on									
Value	2 ⁰ (1)	2 ¹ (2)	2 ² (4)	2 ³ (8)	2 ⁴ (16)	2 ⁵ (32)									

Factory default, Adres 63

Baud rate - DIP 7 & 8

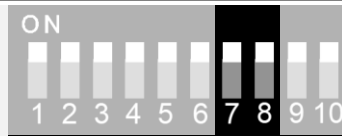
	<table border="1"> <thead> <tr> <th>7</th> <th>8</th> <th>Baud rate</th> </tr> </thead> <tbody> <tr> <td>off</td> <td>off</td> <td>9600</td> </tr> <tr> <td>on</td> <td>off</td> <td>19200</td> </tr> <tr> <td>off</td> <td>on</td> <td>38400</td> </tr> <tr> <td>on</td> <td>on</td> <td>57600 (factory default)</td> </tr> </tbody> </table>	7	8	Baud rate	off	off	9600	on	off	19200	off	on	38400	on	on	57600 (factory default)
7	8	Baud rate														
off	off	9600														
on	off	19200														
off	on	38400														
on	on	57600 (factory default)														

Parity / Stop bits - DIP 9 & 10

	<table border="1"> <thead> <tr> <th>9</th> <th>10</th> <th>Parity</th> </tr> </thead> <tbody> <tr> <td>off</td> <td>off</td> <td>None – 2-Stop bits</td> </tr> <tr> <td>on</td> <td>off</td> <td>Even – 1 Stop bit</td> </tr> <tr> <td>off</td> <td>on</td> <td>Odd – 1 Stop bit</td> </tr> <tr> <td>on</td> <td>on</td> <td>None – 1-Stop bit (factory default)</td> </tr> </tbody> </table>	9	10	Parity	off	off	None – 2-Stop bits	on	off	Even – 1 Stop bit	off	on	Odd – 1 Stop bit	on	on	None – 1-Stop bit (factory default)
9	10	Parity														
off	off	None – 2-Stop bits														
on	off	Even – 1 Stop bit														
off	on	Odd – 1 Stop bit														
on	on	None – 1-Stop bit (factory default)														

» CONTROL FUNCTIONS

In the factory default settings, the brightness of all LEDs during an interaction is 100%. After a configurable time, the LEDs go into standby mode and the brightness is dimmed down to a configurable value until the next interaction.

Address/Access	Description	Factory default	Resolution /Unit	
1200 R/W	Brightness of LEDs in active state (interaction)	100=100% (default)	1.0	%
1201 R/W	Brightness of the LEDs in standby mode	100=100% (default)	1.0	%
1202 R/W	Change to standby mode after x seconds	120=120 Sec. (default)	1.0	Sec.

NOVOS 3 INC TD | Button for room occupancy

Pressing the button switches the room occupancy. As status feedback, the push-button LED can be switched on when the room is occupied.

Address/Access	Description
100 R/W	Room occupancy 0 = unoccupied 1 = occupied
1307 R/W	Room occupancy after Power-On Reset 0 = unoccupied 1 = occupied (default)
426 R/W	LED behavior 0 = LED Off 1 = LED On 2 = Room occupancy (occupied = LED On unoccupied = LED Off)
427 R/W	Button LED color 1 = white 2 = LED Off 3 = red 4 = green 5 = blue 6 = yellow 7 = magenta 8 = turquoise

NOVOS 3 INC



NOVOS 3 INC TD



NOVOS 3 INC FS5



7 LEDs indicate the status of the currently adjusted setpoint. The LED display scales automatically to the set setpoint adjustment range.

Example: Coloring of the LEDs

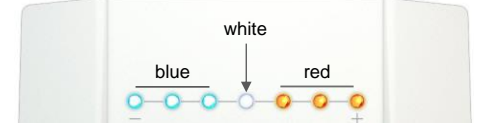

Rotary/press encoder

One control element with 2 functions. The target value can be adjusted by turning.

Address/Access	Description
103 R/W	Set point (effective) 700 = 70,0 °C
1302 R/W	Base set point 700 = 70,0 °C (default)
1303 R/W	Set point adjustment range 38 = ±38,0 °F (default) <i>It makes sense to adapt the setpoint adjustment range of the NOVOS 3 INC to the number of LEDs.</i>
1304 R/W	Set point step width 5 = 0,5 °F (default)
1305 R/W	ECO button function 0 = no 1 = yes

Press to activate/deactivate the ECO function.

It is no longer possible to adjust the setpoint or fan levels in the active ECO mode.

When a configuration is made, the ECO Mode is stopped (green LED is disabled)

In ECO mode, the set setpoint offset is retained and the fan stage switches to automatic mode.

Address/Access	Description
101 R/W	ECO function 0 = not active 1 = active

NOVOS 3 INC TD FS5 | Button for fan stages

Press the key to set the fan level. The individual fan levels are "toggled".

Address/Access	Description
104 R/W	Fan stage 0 = Off 1 = Stage 1 2 = Stage 2 3 = Stage 3 6 = Stage Auto
1310 R/W	Fan stage Auto available 0 = no 1 = yes (default)
1312 R/W	Fan stage after Power-On Reset 0 = Off 1 = Stage 1 2 = Stage 2 3 = Stage 3 6 = Stage Auto

Example: Coloring of the LEDs



In ECO mode the color of the basic setpoint LED and the auto fan level LED changes to green.



» MODBUS DATA ADDRESSES

Address	Access	Description	Resolution / Unit
501	R	relative humidity 850 = 85,0 %rH	Offset Address 2111 1=0,1% 0.1 %rH
505	R	CO2	Offset Address 2511 1=1 ppm 1.0 ppm
506	R	VOC	Offset Address 2611 1=0,1 % 0.1 %
507	R	CO2 / VOC MIX	Offset Address 2711 1=0,1 % 0.1 %
514	R	Status digital input 0 = open 1 = closed	

Register 1100 = 1 (Unit SI)

Address	Access	Description	Resolution / Unit
500	R	Temperature 210 = 21,0 °C	Offset Address 2011 1=0,1 °C SI 0.1 °C
502	R	Absolute humidity 1500 = 15,00 g/m ³	Offset Address 2211 1=0,01 g/m ³ SI 0.01 g/m ³
503	R	Enthalpy 550 = 55,0 kJ/kg	Offset Address 2311 1=0,1 KJ/kg SI 0.1 kJ/kg
504	R	Dew point 180 = 18,0 °C	Offset Address 2411 1=0,1 °C SI 0.1 °C

Register 1100 = 2 (Unit Imperial)

Address	Access	Description	Resolution / Unit
500	R	Temperature 700 = 70,0 °F	Offset Address 2011 1=0,1 °F Imperial 0.1 °F
502	R	absolute humidity 4200 = 4,2 gr/ft ³	Offset Address 2211 1=0,01 gr/ft ³ Imperial 0.01 gr/ft ³
503	R	Enthalpy 240 = 24,0 BTU/lb	Offset Address 2311 1=0,1 BTU/lb Imperial 0.1 BTU/lb
504	R	dew point 600 = 60,0 °F	Offset Address 2411 1=0,1 °F Imperial 0.1 °F

» DIMENSIONS (MM | IN.)

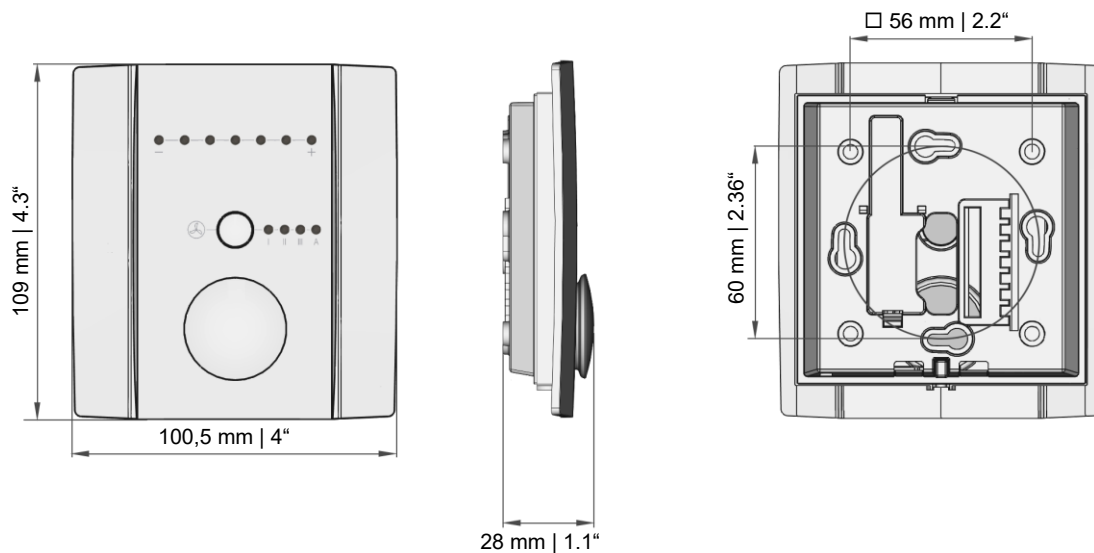

» ACCESSORIES (OPTIONAL)

Rawplugs and screws (2 pcs. each)
 PSU-UP24 – flush mount power supply 24 V (AC Input: 100..240 V ~ | DC Output 24 V = 0,5 A)
 Mounting bracket (surface mounted) white
 Mounting bracket (surface mounted) black

Item No. 102209
 Item No. 645737
 Item No. 795050
 Item No. 795074

Bluetooth dongle
 Thermokon USB-Interface
 USB RS485 Modbus RTU Logger
 USB Interface RS485 (incl. driver CD)
 RS485 Biasing Adapter

Item No. 668262
 Item No. 597838
 Item No. 809917
 Item No. 668293
 Item No. 811378