

AKF10+ Basic RS485 Modbus

Duct-/Immersion temperature sensor

thermokon[®]
HOME OF SENSOR TECHNOLOGY

Datasheet

Subject to technical alteration
Issue date: 29.08.2022 • A123



» APPLICATION

Duct/Immersion sensor for measurement of air temperature and other gaseous mediums for HVAC applications (e.g. supply and exhaust ducts).
Can be used as an immersion temperature sensor combined with a thermowell pocket.

» TYPES AVAILABLE

Duct/Immersion sensor temperature – active BUS

- AKF10+ Basic RS485 Modbus <xxx>.06

<xxx>: mounting length 50/100/150/200/250/300/450 mm

» SECURITY ADVICE – CAUTION

The installation and assembly of electrical equipment should only be performed by authorized personnel.



The product should only be used for the intended application. Unauthorised modifications are prohibited! The product must not be used in relation with any equipment that in case of a failure may threaten, directly or indirectly, human health or life or result in danger to human beings, animals or assets. Ensure all power is disconnected before installing. Do not connect to live/operating equipment.

Please comply with

- Local laws, health & safety regulations, technical standards and regulations
- Condition of the device at the time of installation, to ensure safe installation
- This data sheet and installation manual

» PRODUCT TESTING AND CERTIFICATION



Declaration of conformity

The declaration of conformity of the products can be found on our website <https://www.thermokon.de/>

» NOTES ON DISPOSAL



As a component of a large-scale fixed installation, Thermokon products are intended to be used permanently as part of a building or a structure at a pre-defined and dedicated location, hence the Waste Electrical and Electronic Act (WEEE) is not applicable. However, most of the products may contain valuable materials that should be recycled and not disposed of as domestic waste. Please note the relevant regulations for local disposal.

» GENERAL REMARKS CONCERNING SENSORS

Especially with regard to passive sensors in 2-wire conductor versions, the wire resistance of the supply wire has to be considered. If necessary the wire resistance has to be compensated by the follow-up electronics. Due to self-heating, the wire current affects the measurement accuracy, so it should not exceed 1 mA.

When using lengthy connection wires (depending on the cross section used) the measuring result might be falsified due to a voltage drop at the common GND-wire (caused by the voltage current and the line resistance). In this case, 2 GND-wires must be wired to the sensor - one for supply voltage and one for the measuring current.

Sensing devices with a transducer should always be operated in the middle of the measuring range to avoid deviations at the measuring end points. The ambient temperature of the transducer electronics should be kept constant. The transducers must be operated at a constant supply voltage ($\pm 0,2$ V). When switching the supply voltage on/off, onsite power surges must be avoided.

» BUILD-UP OF SELF-HEATING BY ELECTRICAL DISSIPATIVE POWER

Sensors with electronic components always have a dissipative power, which affects the temperature measurement of the ambient air. The dissipation in active temperature sensors shows a linear increase with rising operating voltage. This dissipative power has to be considered when measuring temperature. In case of a fixed operating voltage ($\pm 0,2$ V) this is normally done by adding or reducing a constant offset value.

Thermokon transducers can be operated with variable operating voltages. The transducers are set at the factory with a reference operating voltage of 24 V =.

At this voltage, the expected measuring error of the output signal will be the least. Other operating voltages, can cause a measurement deviation changing power loss of the sensor electronics.

A recalibration can be carried out directly on the unit or via a software variable (app or bus).

Remark: Occurring draught leads to a better carrying-off of dissipative power at the sensor. Thus temporally limited fluctuations might occur upon temperature measurement.

» USE ENCLOSURE WITH UV AND WEATHER RESISTANCE

After some time, outdoor mounted plastics can lose their color and quality. Therefore, all USE housings are made of special white polycarbonate (PC). The light-stable colorants and additives are used to achieve optimum protection of the polymer while maintaining color stability. The titanium dioxide used is specially developed for polycarbonate and offers excellent UV protection through the reflection of the entire light spectrum including the UV component by 340 nm. This effectively counteracts the otherwise occurring photochemical polymer degradation. The colors stay full for a long time without fading. The material is also resistant to cold and frost.

» MOUNTING ADVICES

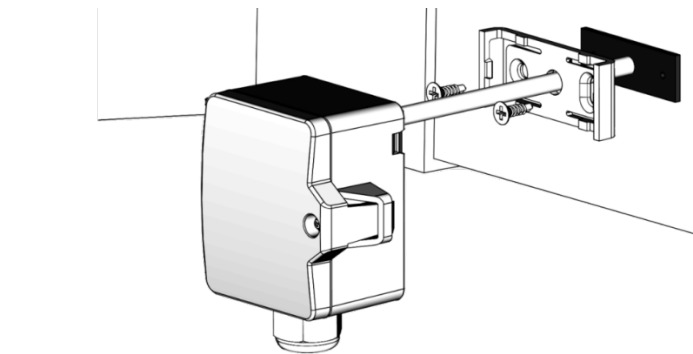

The sensor can be mounted on the ventilation duct by means of the mounting clip. For risk of condensate permeation in the sensor tube respectively in the immersion pocket the bushing must be installed in a position that occurred condensate can run off.

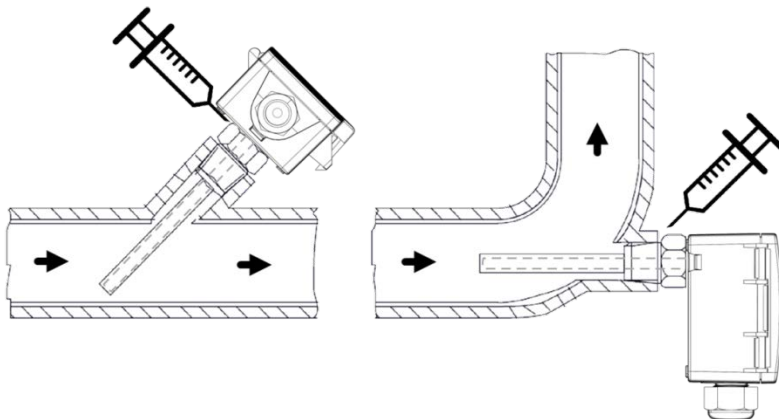

Mounting with immersion pocket or compression fitting for usage in liquid media. Use contact fluid for better heat transfer between sensor and measuring medium.

» **TECHNICAL DATA**

Measuring values	temperature		
Network technology	RS485 Modbus, RTU or ASCII, half-duplex, baud rate 9.600, 19.200, 38.400 or 57.600, parity: non (2 stopbits), even or odd (1 stopbit), Fail-safe Biasing required		
Power supply	15..24 V = (±10%) (or 24 V ~ (±10%))* SELV		
Power consumption	max. 0,7 W (24 V =) 1,8 VA (24 V ~) SELV		
Operating temperature range <i>* Max. permissible operating temperature</i>	sensor pocket -50..+160 °C optional -80..+260 °C	enclosure -35..+70 °C	mounting clip base -35..+90 °C
Accuracy temperature	±0,5 K (typ. at 25 °C)		
Enclosure	enclosure USE-S, PC, pure white, UV resistant		
Protection	IP65 according to EN 60529, SI-Protection		
Cable entry	Flextherm M20, for wire Ø=4,5..9 mm, removable		
Connection electrical	removable plug-in terminal, max. 2,5 mm ²		
Pocket	stainless steel V4A, Ø=6 mm, mounting length: 50 100 150 200 250 300 450 mm		
Ambient condition	max. 85% rH short term condensation		
Mounting	with duct temperature of +90..120 °C mounting flange MF6 flexible, at +120..260 °C mounting flange MF6 (brass) is recommended		

» **CONNECTION PLAN AND CONFIGURATION**

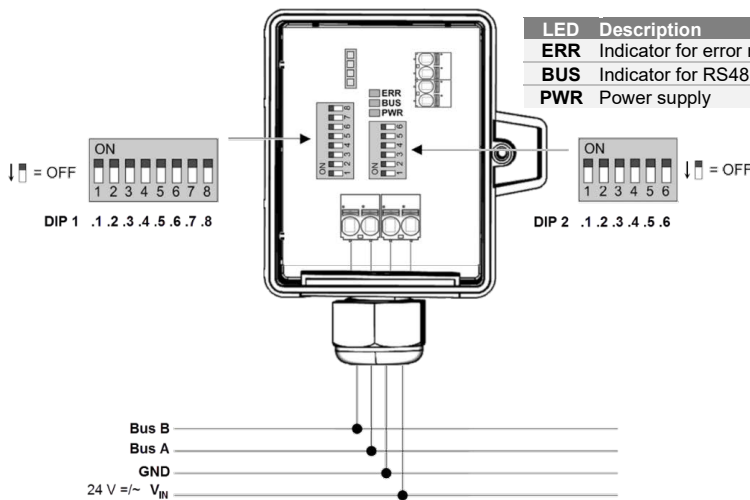

***Power supply**

When several BUS devices are supplied by one 24 V AC voltage supply, it is to be ensured that all "positive" operating voltage input terminals (+) of the field devices are connected with each other and all "negative" operating voltage input terminals (-) (=reference potential) are connected together (in-phase connection of field devices). In case of reversed polarity at one field device, a supply voltage short-circuit would be caused by that device. The consequential short-circuit current flowing through this field may cause damage to it.



Pay attention to correct wiring.

Dip switch block 1: Device Address binary coded (address range 1..247)

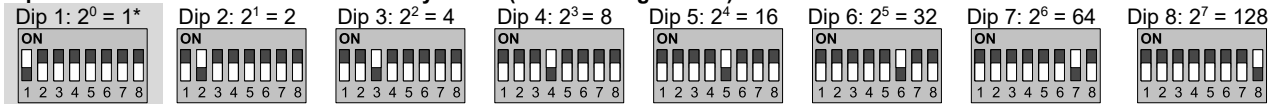

** factory default settings*

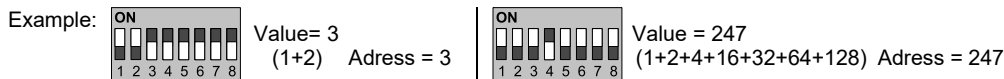

Dip switch block 2: Modbus interface settings

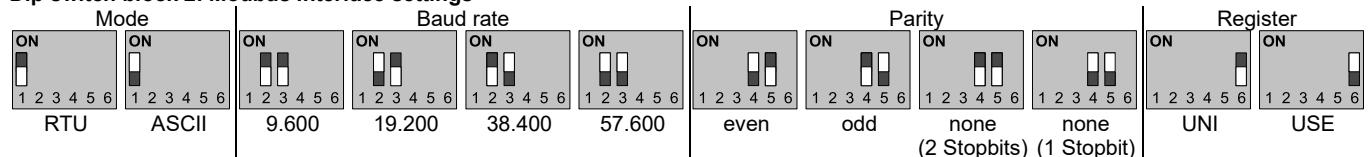

Factory default

Device address: 1 | RTU | Baud rate: 9.600 | Parity: even | Register addressing: USE

Register compatibility to USE (Valid from firmware version 1.4, Jan. 2020)

Via dipswitch 2.6 it is possible to change between the previous register addressing of the UNI-Modbus board to a USE compatible register assignment. The function of the device does not change.

When using ASCII mode, parity must be set to EVEN or ODD. „No Parity“ (no) is not available in ASCII mode.

» RS485 MODBUS REGISTER**Variant 1 (UNI-Modbus) DIP 2.6 = OFF**

Data address	Function code	Description	Type
0 _{dec} 0x0000 _{hex}	3 (R)	Firmware z.B.: 0x1000 = Version 1.0.0.0	SIGNED 16 Bit
1 _{dec} 0x0001 _{hex}	4 (R/W)	Device Location	SIGNED 16 Bit
580 _{dec} 0x244 _{hex}	3 (R)	Temperature [1/100] °C	SIGNED 16 Bit
581 _{dec} 0x245 _{hex}	3 (R)	Temperature [1/100] °F	SIGNED 16 Bit
5 _{dec} 0x0005 _{hex}	4 (R/W)	Offset temperature [1/100] K	SIGNED 16 Bit

Variant 2 (USE-Modbus) DIP 2.6 = ON

Data address	Function code	Description	Type
503 _{dec} 0x01F7 _{hex}	3 (R)	Firmware version i.e.: 0x1300 = Version 1.3.0.0	SIGNED 16 Bit
400 _{dec} 0x0190 _{hex}	4 (R/W)	Unit system 1 = SI 2 = Imperial	SIGNED 16 Bit
0 _{dec} 0x0000 _{hex}	3 (R)	Temperature [1/10] °C/°F	SIGNED 16 Bit
100 _{dec} 0x0100 _{hex}	4 (R/W)	Offset temperature [1/10] K	SIGNED 16 Bit

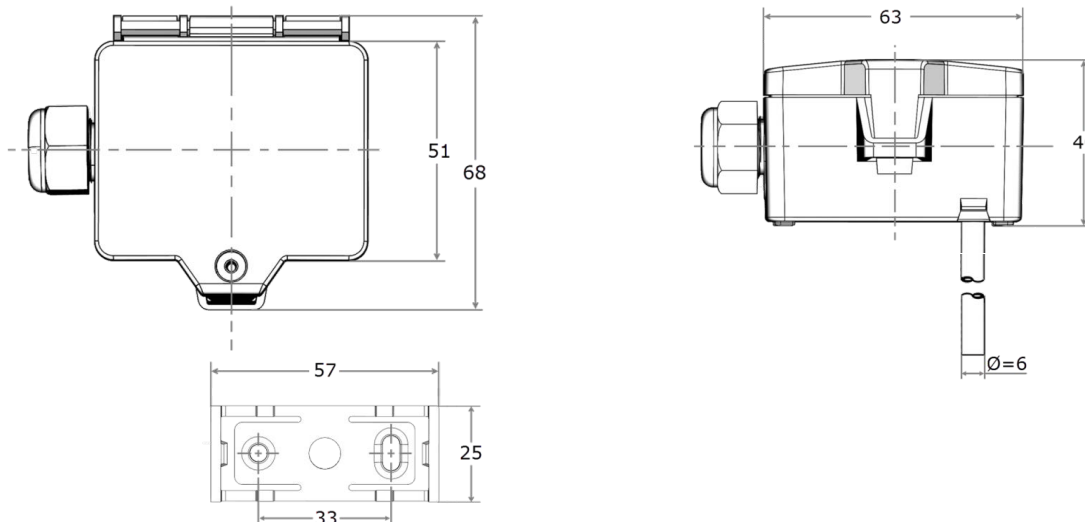
» DIMENSIONS (MM)**» ACCESSORIES (INCLUDED IN DELIVERY)**

Mounting kit AKF10+

• Cover screw + screw cover • 2 Screws • mounting clip + self-adhesive seal

Item No. 748551

» ACCESSORIES (OPTIONAL)

VA-Compression fitting type KL6VA (suitable for 6 mm)

Item No. 103213

Mounting base enclosure USE pure white

Item No. 667722

Mounting flange MF6 flexible (suitable for Ø=4 | 6 | 7 mm)

Item No. 399098

Mounting flange MF6, brass (suitable for Ø=6 mm)

Item No. 003407

Syringe thermal contact fluid

Item No. 102308

Sealing insert M20 USE white, 2x Ø=7 mm (for 2 wire; PU 10 pieces)

Item No. 641333

USB RS485 Modbus RTU Logger

Item No. 809917

Thermowell pockets stainless steel / brass for sensors with pocket Ø=6 mm

length	50 mm	100 mm	150 mm	200 mm	250 mm	300 mm	450 mm
THMSDS	610995	611008	611015	611022	611763	611039	611046
THVADS	611152	611817	611824	611848	611862	611879	611893

MS-thermowell (brass, permitted up to 16 bar) type THMSDS <xx> | VA-thermowell (stainless steel, permitted up to 40 bar) type THVADS <xx>.