

LS02+

Leakage Sensor

thermokon[®]
HOME OF SENSOR TECHNOLOGY

Datasheet

Subject to technical alteration

Issue date: 03.04.2024 • A140 • 727440



» APPLICATION

Leakage sensor for the detection of electrically conductive liquids with LED signal and relay output. Designed for alarm, control and monitoring applications.

» TYPES AVAILABLE

Water leak detection sensor

- LS02+

» SECURITY ADVICE – CAUTION



The installation and assembly of electrical equipment should only be performed by authorized personnel.

The product should only be used for the intended application. Unauthorised modifications are prohibited! The product must not be used in relation with any equipment that in case of a failure may threaten, directly or indirectly, human health or life or result in danger to human beings, animals or assets. Ensure all power is disconnected before installing. Do not connect to live/operating equipment.

Please comply with

- Local laws, health & safety regulations, technical standards and regulations
- Condition of the device at the time of installation, to ensure safe installation
- This data sheet and installation manual

» PRODUCT TESTING AND CERTIFICATION



Declaration of conformity

The declaration of conformity of the products are available on our website
<https://www.thermokon.de/direct/en-gb/categories/ls02plus>

» GENERAL REMARKS CONCERNING SENSORS

Especially with regard to passive sensors in 2-wire conductor versions, the wire resistance of the supply wire has to be considered. If necessary the wire resistance has to be compensated by the follow-up electronics. Due to self-heating, the wire current affects the measurement accuracy, so it should not exceed 1 mA.

When using lengthy connection wires (depending on the cross section used) the measuring result might be falsified due to a voltage drop at the common GND-wire (caused by the voltage current and the line resistance). In this case, 2 GND-wires must be wired to the sensor - one for supply voltage and one for the measuring current.

Sensing devices with a transducer should always be operated in the middle of the measuring range to avoid deviations at the measuring end points. The ambient temperature of the transducer electronics should be kept constant. The transducers must be operated at a constant supply voltage ($\pm 0,2$ V). When switching the supply voltage on/off, onsite power surges must be avoided.

» TECHNICAL DATA

Measuring values	leakage	
Output switch contact	changeover contact, 24 V: max. 24 V / 1,0 A (resistive, floating)	
Power supply	15..24 V = ($\pm 10\%$) or 24 V ~ ($\pm 10\%$) SELV	
Power consumption	typ. 0,6 W (24 V =) 1,5 VA (24 V ~)	
Sensor	2x2 detector electrodes stainless steel V2A	
Display	PWR - LED green power supply OK,	DETECT - LED red alarm, leakage detected
Enclosure	enclosure USE-S PC, pure white,	Cover PC, transparent
Protection	IP65 according to EN 60529	
Cable entry	Flextherm M20, for wire $\varnothing=4,5..9$ mm, removable	
Connection electrical	removable plug-in terminal, max. 2,5 mm ²	
Ambient condition	-35..+70 °C, max. 85% rH short term condensation	
Switching threshold conductivity	ca. 10 μ S	
Mounting	adjustment in height is possible using adjustable contacts	

» NOTES ON DISPOSAL



The crossed-out wheeled bin symbol indicates that the product or removable batteries must not be disposed of with household or commercial waste. Within the EU, you are legally obliged to dispose of the product separately and appropriately in accordance with the national laws of your country. Alternatively, please contact your supplier or Thermokon Sensortechnik GmbH. Further information can be found at: www.thermokon.com

» MOUNTING ADVICES

Depending on their type and concentration, corrosive liquids and liquids containing solvents can damage the sensor and lead to incorrect measurements. Contamination can also lead to incorrect measurements.

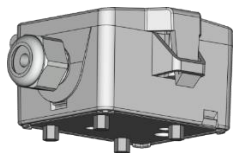

LS02+



Height
adjustment
removed



Height
adjustment
mounted

The leakage sensor contains an enclosure with a cable entry and four detector electrodes including a height adjustment screw. The adjustment screws are electrically insulated and no surface condensation is detected.

Only the plastic adjustment screw (isolation) and not the metallic detector electrodes (hexagon bolt) may be rotated.

Installation with Mounting bracket:

Remove the adjustment screws to use the mounting bracket. The mounting bracket is screwed to the ground and the enclosure is clipped in. The detection electrodes are in operation height.

Installation without Mounting bracket:

The leakage sensor with the detector electrodes is positioned on a leveled ground. The height adjustment screws are variably adjustable (2...4 mm) to the local conditions.

» CONNECTION PLAN

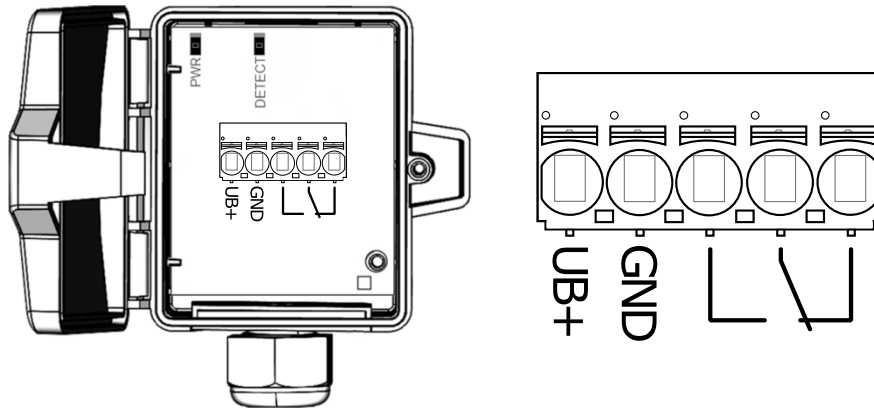

The representation of the relay contact indicates the operating state "Devices connected to voltage supply and no leakage is detected". The contacts 4 and 5 are connected. The relay is energized in this operating state. When fluids are detected or when switching off the operating voltage, it falls off.

» DIMENSIONS (MM)

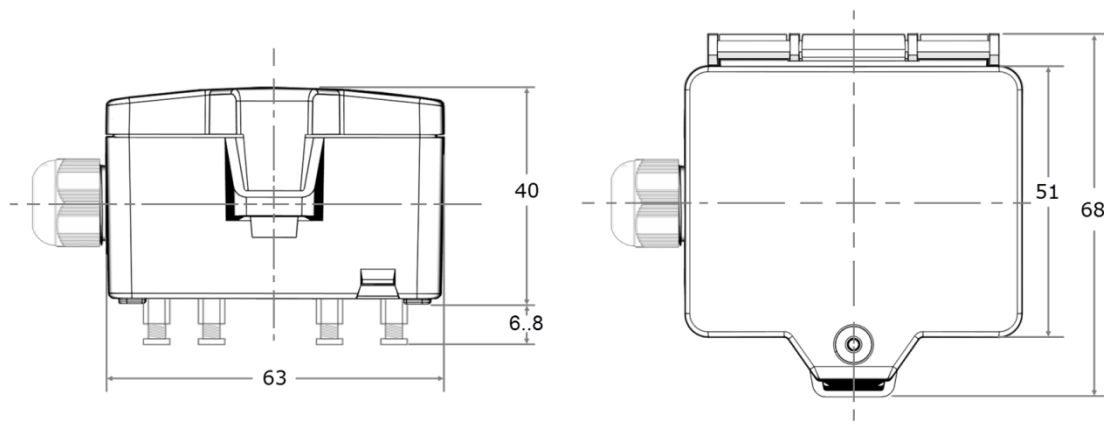

» ACCESSORIES (OPTIONAL)

Sealing insert M20 USE white, 2x $\varnothing=7$ mm (for 2 wire; PU 10 pieces)
Mounting bracket

Item No. 641333
Item No. 667722