

LCF02 5DO RS485 Modbus

Fancoil controller (flush mounting)
valid from version 1.1.5

thermokon[®]
HOME OF SENSOR TECHNOLOGY

Datasheet

Subject to technical alteration
Issue date: 04.09.2024 • A140



» APPLICATION

The fancoil room controller has been designed for individual control of temperature in commercial, industrial and residential buildings. It is tailored for two-pipe fan coil with two-wire electric valves. With its flush mounted modern design the device combines digital technology with a large LCD display and additional buttons, which enables the single room controller to be used intuitively.

» SECURITY ADVICE – CAUTION

The installation and assembly of electrical equipment should only be performed by authorized personnel.



The product should only be used for the intended application. Unauthorised modifications are prohibited! The product must not be used in relation with any equipment that in case of a failure may threaten, directly or indirectly, human health or life or result in danger to human beings, animals or assets. Ensure all power is disconnected before installing. Do not connect to live/operating equipment.



CAUTION! Risk of electric shock due to live components within the enclosure, especially devices with mains voltage supply (usually between 90..265 V).

Please comply with

- Local laws, health & safety regulations, technical standards and regulations
- Condition of the device at the time of installation, to ensure safe installation
- This data sheet and installation manual

» NOTES ON DISPOSAL



The crossed-out wheeled bin symbol indicates that the product or removable batteries must not be disposed of with household or commercial waste. Within the EU, you are legally obliged to dispose of the product separately and appropriately in accordance with the national laws of your country. Alternatively, please contact your supplier or Thermokon Sensortechnik GmbH. Further information can be found at: www.thermokon.com

» MOUNTING ADVISE ROOM SENSORS

The Accuracy of the room sensors are influenced by the technical specifications as well as the positioning and the installation type.

During Assembly:

- Seal mounting box (if present).
- Installation type, air draught, heat source, radiation heat or direct sunlight can affect the measurement.
- Bulding material specific properties of the installation place (brick-, concrete-, partition wall, cavity wall, ...) can affect the measurement.

Assembly not recommendet in...

- Air draught (e.g.: close to windows / doors / fans ...)
- Near heating sources,
- Direct sunlight
- Niches / between furniture / ...

» TECHNICAL DATA

Measuring values	temperature		
Output switch contact	terminal 2 3 (for heating/cooling 2-point control or PWM) 2 normally open contacts, max. 250 V ~ / 3 A max. 30 V = / 3 A	terminal 5 6 7 – LO ME HI (for Fan) 3x normally open contact, max. 250 V ~ / 3 A max. 30 V = / 3 A	
Network technology	RS485 Modbus, RTU, half-duplex, baud rate 4.800, 9.600, 19.200 or 38.400, parity: non (2 stopbits), even or odd (1 stopbit) RS485-Bus load: 1 unit load according RS485-standard (max. 32 devices)		
Power supply	24 V = (±10%) 24 V ~ (±20%) SELV		
Power consumption	3 W (24 V =)		
Measuring range temp.	+1..+50 °C		
Accuracy temperature	±1 K (typ. at 21 °C)		
Inputs	terminal 10 input for external sensor NTC10K	terminal 11 – ESI DP input digital for floating contact, window contact, dew point sensor	terminal 12 - OCC input digital for floating contact, occupancy sensor, key card switch
Control functions	set point adjustment +1..+50 °C, (default +16..+30 °C)		
Display	LCD 64x41 mm, white background lighting		
Enclosure	ABS, pure white		
Protection	IP20 according to EN 60529		
Cable entry	rear entry		
Connection electrical	terminal block max. 1,5 mm ²		
Ambient condition	-10..+50 °C, max. 95% rH non-condensing		
Weight	160 g		
Mounting	flush mounted with standard EU box (Ø=60 mm)		

» PRODUCT TESTING AND CERTIFICATION



Declaration of conformity

The declaration of conformity of the products are available on our website
<https://www.thermokon.de/direct/en-gb/categories/lcf02>

» CONNECTION PLAN

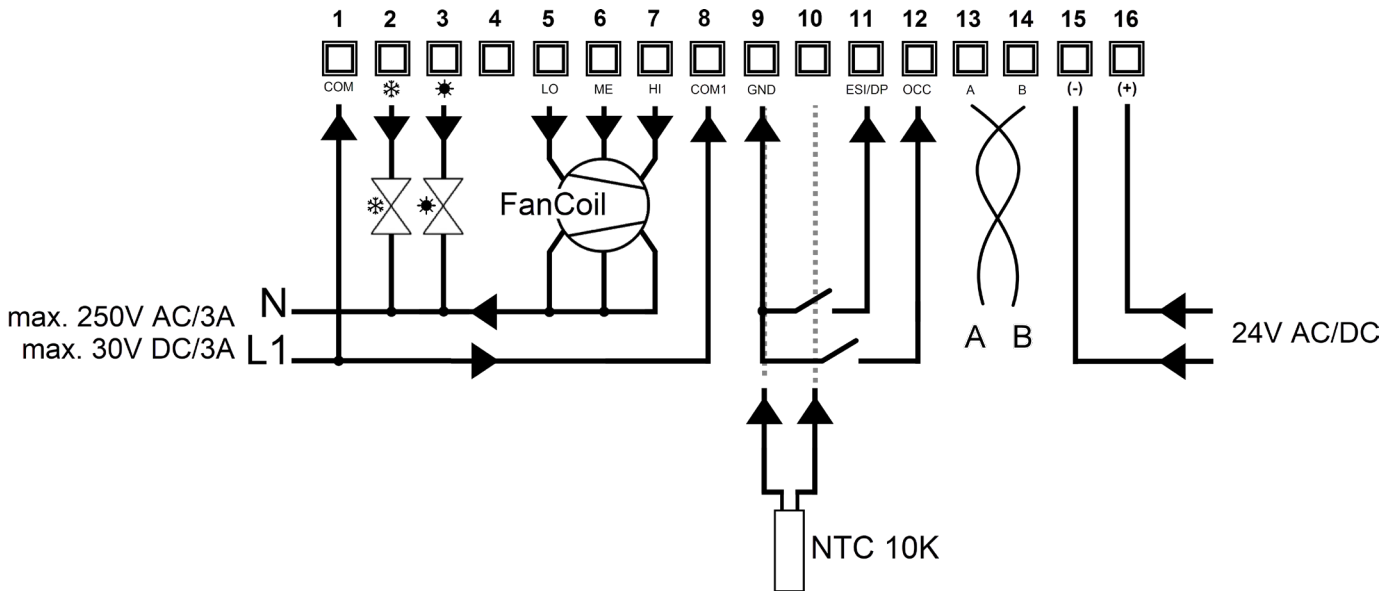

Power supply

When several BUS devices are supplied by one 24 V AC voltage supply, it is to be ensured that all “positive” operating voltage input terminals (+) of the field devices are connected with each other and all “negative” operating voltage input terminals (-) (=reference potential) are connected together (in-phase connection of field devices).

In case of reversed polarity at one field device, a supply voltage short-circuit would be caused by that device. The consequential short-circuit current flowing through this field may cause damage to it.

Therefore, pay attention to correct wiring.

Controller output signal

		4-pipe (default)	2-pipe
Terminal 2	❄️	Cooling	Heating & Cooling
Terminal 3	☀️	Heating	

» DISPLAY PANEL

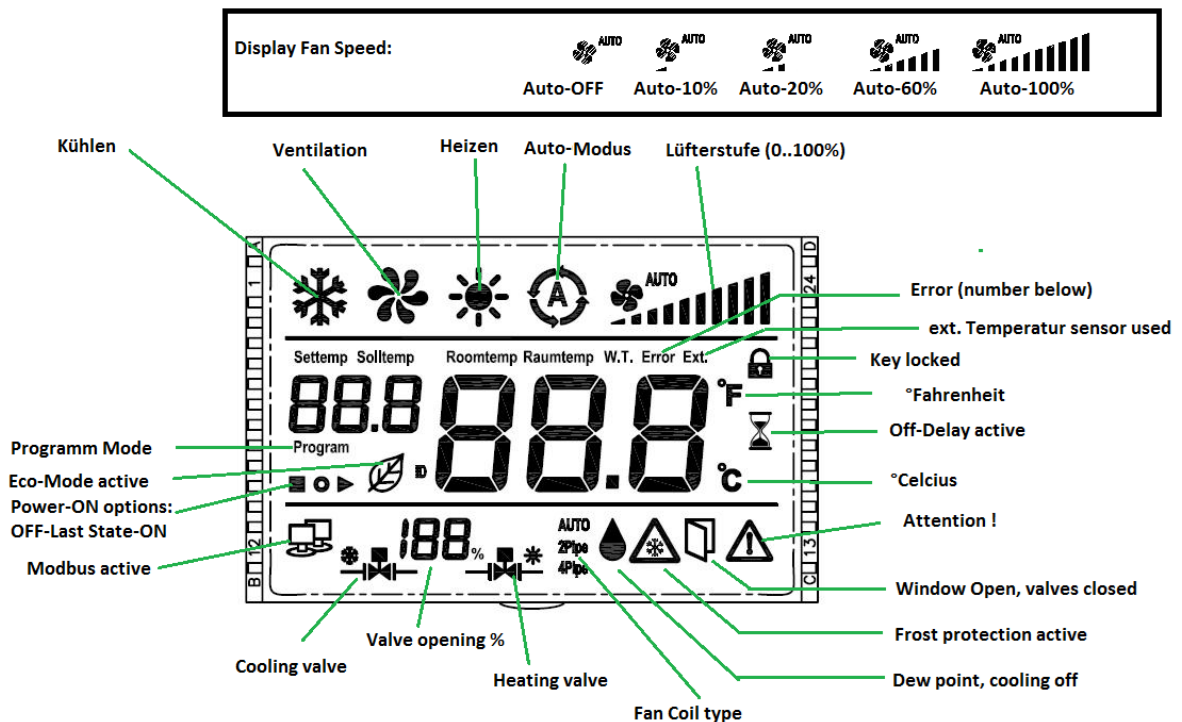

» **FUNCTION DESCRIPTION**

Communication factory default

Modbus-adress:	1		
Communication-interface:	RS485	Communication-protocol:	Modbus-RTU
Baud Rate:	9600	Parity:	No parity
Data:	8 bit	Stop:	2 bit

Device informationen

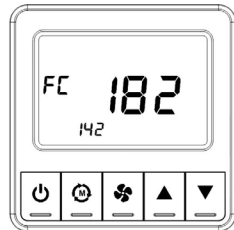

The device information (version and type number) are displayed on the start screen for a short time.

Communication



symbol flashes (If the device does not communicate via the bus, the symbol will be disappear after 10 seconds)

Parameter menu



To enter the parameter menu (i.e. for Modbus-communication settings):
 - Press and hold "mode"-button for 5 seconds.
 - Enter password: **(default: 987)**
 o Digit selection: mode-button
 o Arrow keys (▲/▼): increase / decrease value
 - Select parameter with arrow keys



After parameter selection / setting, don't press any button for 3 seconds to save the settings.

No.	Parameter	Description	default
1	Modbus Adress	ID.1- ID.247	1
2	Baud rate	1 = 4800bps 2 = 9600 3 = 19200 4 = 38400	2
3	Parity	0 = none 1 = even 2 = odd	0
4	Stop Bits	1 = 1 Stopbit 2 = 2 Stopbits	2
5	Temperature Offset internal sensor	-5,0 K..+5,0 K	0
6	Temperatur Offset external sensor	-5,0 K..+5,0 K	0
7	Piping system	0 = 2-pipe 1 = 4-pipe	1
8	Factory reset	- Set parameter to 1 - Press mode key - Device is factory reset. <i>(Device stays in Parameter menu for Modbus configuration)</i>	0

Heating/ cooling with 2-point-/ 3-point-controller (Register address 0x0130)

In the case of temperature control, the 2-point controller only knows the switching states heating ON and heating OFF. The 3-point controller also knows the switching state of cooling. Two - and three-point controller work with a hysteresis.

Heating/ cooling with PI-controller (PWM) (Register address 0x0130)

The time response of the PI control loop depends on the control parameters xp for the proportional area and tn for the reset time of the integral range. In case of an error, the P portion immediately changes the position value proportionally to the error variable, while the integral portion takes effect after a certain time. The resulting actuating variable is output as a pulse-width-modulated signal directly to the outputs.

» OPERATING MODE

Press the "Mode Key"  , to adjust the mode cyclically (Cooling > Ventilating > Auto mode > Heating ...).

In 2-pipe configuration not available modes (depending on the change-over sensor's signal) will be skipped. In this case the user can select the available modes only.

Standby / ECO / ON

The Power-Button switches the device from Stand-by to ON. In Standby the display is off, but the control loop is actively monitoring the temperature and will activate the heating output if the room temperature drops below the frost protection threshold.

Pressing the button once switches the display on and the device to ECO mode. In ECO mode it controls the room temperature to the setpoint predefined by register 275 and 276 (0x0113, 0x0114). The display will show the average of both ECO Setpoint Temperatures (25+18 /2=21,5) and the leaf symbol to indicate the ECO mode. In ECO mode the setpoint is fixed and the device does not react to any button pressed by the user besides pressing the Stand-by /ECO/ON button a 2nd time. Then it will switch from ECO to comfort mode. To indicate that the Fancoil thermostat is in ECO mode it will show the leaf and the word ECO in the display.

In case an occupancy sensor is connected to one of the inputs the mode will change from ECO to comfort as soon as the input becomes active and the previously used Setpoint will be restored and the leaf symbol will not be showing any more.

Temperature sensor input – temperature limiter and external sensor

The temperature sensor input (address 0x0152) can be used as change over sensor (addresses 0x012B and 0x012C) or as external temperature sensor.

Furthermore, it can also be used to limit the heating temperature (address 0x010A) and cooling temperature (address 0x010B). This is the case for floor heating systems, where the external sensor is embedded in the floor. In case the floor temperature will exceed a certain threshold the heating valve shall be closed to avoid damaging the floor or the pipes embedded in the floor.

Fan control

If the fan is configured to be 1-stage or 2-stage the selection will be adapted accordingly. In „ventilating mode“, the valves will be closed. If the fan

speed  is set to Auto the steps are switched depending on the temperature difference between the setpoint value and the current temperature value.

In auto mode heating or cooling, the fan level is calculated from the output of the PI loop (control variable).

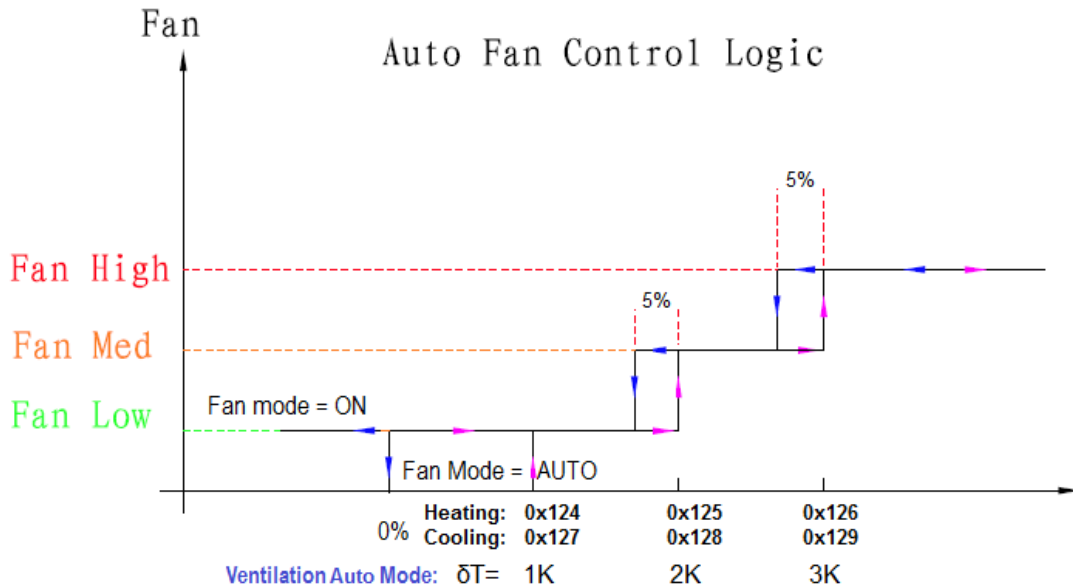

°F/°C selective

Temp display range is 32 °F..99 °F, respectively 0 °C..50 °C (factory default is °C). By simultaneously pressing the keys "▲" and "▼" the display of the unit system can be switched directly on the LCD.

Temperature offset correction (Register address 0x0106)

The internal sensor will be affected by the Thermostat's self-heating. As a consequence it would display a higher room temperature than the average of indoor temperature (real value). Item 5 & 6 of the parameter table does contain the correction of temperature offset (resolution 0,1 °C).

Set the Temperature set point range (Register address 0x0110 – 0x0112)

Press "▲" or "▼" key to adjust the temperature set point range. Factory default (°C) is 16 °C..30 °C.

Key lock selection (Register address 0x010D)

If a key is pressed that is locked, the lock symbol  will appear for 2s and blink 2x but no further action is taken.

Power failure – Restart selection (Register address 0x010C)

Symbol Description



Keep thermostat switched OFF



Switch thermostat to last state before power failure (Record and Memorize)



Turn the thermostat ON

Storage during power loss

The status will be kept in EEPROM, while the power failure, so no data will be lost.

The setpoint is not saved. The standard setpoint after power-on reset applies, register address 271 (0x010F).

Occupancy (OCC)

If the input is configured for an Occupancy sensor. If the sensor indicates "UnOccupied" the current setpoint will be replaced by the Eco Mode Setpoint Temp. The display will show the leaf symbol and the lettering ECO to indicate the ECO mode. Once the room occupancy is detected again the previously used Setpoint will be restored and the leaf symbol will not be showing any more.

Window contact (ESI)

If the input is configured as window contact, the "Window open" Symbol will be displayed the thermostat will check every 3 seconds the input whether active. The cooling valve will be closed as long as the input will be active. The rest of the thermostat will work as usual, the user may

change the setpoint or the fan stage, but the valve outputs will remain in valve closed position. If configured the "Window open"  or the Dew

Point symbol  will be flashing. When the input will not be active, the thermostat's outputs return to normal operation and operates the outputs normally.

Sensor failure alarm

In case the room NTC temp sensor is open or short, thermostat switches fan to medium and the valve to 50% (5V output, 50% duty cycle for PWM and ON/OFF). The display will show (blinking) error code: "E1" Thermostat will allow to control fan manually as well as the valve output using the "▲" or "▼" keys. Every operation of the "▲" or "▼" keys will decrement / increment the output voltage by 1V = 10% AND the PWM by 10%. The percentage is shown in the display.

Input Register			
Address	Access	Description	Register value \triangleq Value range
0	0x000	R	Thermokon model identification 0x FF00 \triangleq LCF-5DO
1	0x0001	R	Firmware-Version e.g. 0x1110 \triangleq 1.1.1
2	0x0002	R	Back-Box Type 05 \triangleq DOD5R
3	0x0003	R	Value of the integrated temperature sensor °C / °F 0..500 \triangleq 0..50,0°C 300..1200 \triangleq +30,0..+120,0°F
4	0x0004	R	Fan-State 0b00000000 = OFF 0b00000001 = Fan stage low 0b00000010 = Fan stage medium 0b00000100 = Fan stage high 0b00001000 = Auto OFF 0b00001001 = Auto low 0b00001010 = Auto medium 0b00001100 = Auto high
5	0x0005	R	VA1 State – output valve 1 cooling (PWM cycle time ON) 0..1000 \triangleq 0..100%
6	0x0006	R	VA2 State – output valve 2 heating (PWM cycle time ON) 0..1000 \triangleq 0..100%
7			Reserved
8	0x0008	R	External temperature sensor °C / °F 200..+1000 \triangleq -20,0..+100,0°C 0..2100 \triangleq 0,0..+210,0°F
9	0x0009	R	Failure status 0x00= no failure 0x01= control loop temperature sensor alarm 0x02= external temperature sensor high limit alarm – (cablebreak) 0x04= external temperature sensor low limit alarm – (short circuit) 0x08= change over sensor missing alarm
10	0x000A	R	External input 1 – terminal 11 0 = Contact open, 1= Contact closed (i.e. window contact, dew point sensor)
11	0x000B	R	External input 2 – terminal 12 0 = Contact open, 1= Contact closed (i.e. OCC Sensor, keycard-switch)

		Holding Register				
		Address	Access	Description	Register value \triangle Value range	Default
General settings	256	0x0100	R/W	Customer set Device location identification	0..65535	0
	257	0x0101	R/W	LCD temperature Unit 0 =°C 1=°F (converted values)	0..1	0
	258	0x0102	R/W	Beeper Intensity 0=Off 1..5 (Volume)	0..5	5
	259	0x0103	R/W	Backlight intensity (operation)	0..100 \triangle 0..100%	80
	260	0x0104	R/W	Reserved		
	261	0x0105	R/W	Backlight operating delay setting	1..255 \triangle 1..255 Sec. (on)	15
	262	0x0106	R/W	Internal Sensor Temperature Offset (added to measured value)	-50..50 \triangle -5,0..+5,0 [°C] -250..250 \triangle -25,0..+25,0 [°F]	0
	263	0x0107	R/W	external Sensor Temperature Offset (added to measured value)	-50..50 \triangle -5,0..+5,0 [°C] -250..250 \triangle -25,0..+25,0 [°F]	0
	264	0x0108	R/W	Display language 0= german 1= english	0..1	0
	265	0x0109	R/W	Individual passwords setting 001-999 default=987 000 = no password	000..999	987
	266	0x010A	R/W	External temperature (limiter) sensor high limit (338=3, for limiter)	-200..1000 \triangle -20,0..+100,0 [°C] 0..2100 \triangle 0,0..+210,0 [°F]	400 / 110
	267	0x010B	R/W	External temperature (limiter) sensor low limit (338=3, for limiter)	-200..1000 \triangle -20,0..+100,0 [°C] 0..2100 \triangle 0,0..+210,0 [°F]	0 / 320
	268	0x010C	R/W	Power failure 0= keep off after power-on-reset 1= return to last state after power failure 2= switch on after power-on-reset	0..2	1
	269	0x010D	R/W	Key-lock Once a locked key is pressed the LOCK symbol shall be displayed and blink twice. 0x00=unlocked 0x01=lock on/off 0x02=lock mode 0x08=lock fan speed 0x10=lock temp settings + / - 0x1F=lock all keystrokes		0
270	0x010E	R/W	Display settings 0b00000001= show setpoint (if no setpoint is shown, keys are locked) 0b00000010= show room temperature 0b00000100 = show valve symbol 0b00001000 = show PI-loop percentage <i>(if only room temperature or setpoint is shown, then in big numbers)</i>		15	

		Holding Register				
		Address	Access	Description	Register value \triangle value range	default
Set-point settings	271	0x010F	R/W	Default Setpoint after Power On Reset	0..500 \triangle 0,0..+50,0 [°C] 300..1200 \triangle +30,0..+120,0 [°F]	210 / 700
	272	0x0110	R/W	Setpoint temperature lower limit	0..500 \triangle 0,0..+50,0 [°C] 300..1200 \triangle +30,0..+120,0 [°F]	160 / 600
	273	0x0111	R/W	Setpoint temperature upper limit	0..500 \triangle 0,0..+50,0 [°C] 300..1200 \triangle +30,0..+120,0 [°F]	300 / 860
	274	0x0112	R/W	Setpoint increment/decrement value	1..100 \triangle 0,1..10,0 [°C] 1..500 \triangle 0,1..50,0 [°F]	5 / 10
	275	0x0113	R/W	ECO mode temperature setpoint cooling	250..450 \triangle +25,0..45,0 [°C] 750..1100 \triangle +75,0..110,0 [°F]	300 / 860
	276	0x0114	R/W	ECO mode temperature setpoint heating	120..240 \triangle +12,0..24,0 [°C] 50..750 \triangle +5,0..75,0 [°F]	190 / 660

Holding Register						
Address	Access	Description	Register value \triangle Value range	default.		
PI-controller	277	0x0115	R	Controller mode Comfort: 0b0000 0000= Controller off (frost protection active, LCD off) 0b0000 0001= Controller auto mode (heating & cooling) 0b0000 0010= Controller heating mode only 0b0000 0011= Controller cooling mode only 0b0000 0100= ventilating (PI-loop controls fan stages only, valves closed) Regler-Modus ECO: 0b0001 0000= Controller off (Frost protection active) 0b0001 0001= Controller auto mode (heating&cooling) 0b0001 0010= Controller heating mode only 0b0001 0011= Controller cooling mode only 0b0001 0100= ventilating (PI-loop controls fan stages only, valves closed)	1	
	278	0x0116	R/W	Fancoil Typ: 2- or 4-pipe 0b00000000=2-pipe: cooling + heating with change over 0b00000001=4-pipe: cooling + heating / (or if 6WV used)	1	
	279	0x0117	R/W	Fan stages and operation modes 0b00000000 = none (fan key is locked, the fan symbol will be faded on the LCD) 0bxxxx0001 = 1 fan stage 0bxxxx0010 = 2 fan stages 0bxxxx0011 = 3 fan stages 0b0001xxxx = During heating mode fan is disabled 0b0010xxxx = During cooling/ventilation mode fan is disabled 0b0011xxxx = during heating/ cooling mode fan is disabled	3	
	280	0x0118	R/W	Start fan at highest stage for () seconds	0..60 \triangle 0..60 Sek.	0
	281	0x0119	R/W	Fan OFF-Delay 0= fan never stops 1..255 \triangle 1..255 Min after valve closing fan stops for .. minutes.	15	
	282	0x011A	R/W	PWM 0 = for 2 point control 1..255 \triangle 1..255 minutes PWM cycle time	15	
	283	0x011B	R/W	Deadband	1..100 \triangle 0,1..10,0 [°C]	10
	284	0x011C	R/W	Heating Proportional Band Xp_heat	1..100 \triangle 0,1..10,0 [°C]	20
	285	0x011D	R/W	Heating Integration Time Tn_heat	0..255 \triangle 0..255 Minuten	30
	286	0x011E	R/W	Cooling Proportional Band Xp_cool	1..100 \triangle 0,1..10,0 [°C]	20
	287	0x011F	R/W	Cooling Integration Time Tn_cool	0..255 \triangle 0..255 Minuten	30
	288	0x0120	R/W	Minimal limit of the control variable heat	0..100 \triangle 0..100 %	0
	289	0x0121	R/W	Maximal limit of the control variable heat	0..100 \triangle 0..100 %	100
	290	0x0122	R/W	Minimal limit of the control variable cool	0..100 \triangle 0..100 %	0
	291	0x0123	R/W	Maximal limit of the control variable cool	0..100 \triangle 0..100 %	100
	292	0x0124	R/W	Fan stage 1 ON threshold control variable heat	0..100 \triangle 0..100 %	5
	293	0x0125	R/W	Fan stage 2 ON threshold control variable heat	0..100 \triangle 0..100 %	35
	294	0x0126	R/W	Fan stage 3 ON threshold control variable heat	0..100 \triangle 0..100 %	70
	295	0x0127	R/W	Fan stage 1 ON threshold control variable cool	0..100 \triangle 0..100 %	5
	296	0x0128	R/W	Fan stage 2 ON threshold control variable cool	0..100 \triangle 0..100 %	35
	297	0x0129	R/W	Fan stage 3 ON threshold control variable cool	0..100 \triangle 0..100 %	70
	298	0x012A	R/W	Frost protection temperature threshold	50..150 \triangle +5,0..+15,0 °C 400..600 \triangle +40,0..+60,0 °F	70/ 450
	299	0x012B	R/W	Change-Over Temperature Threshold for Heating	0..500 \triangle 0..+50,0 °C 300..1200 \triangle +30,0..+120,0 °F	300/ 860
	300	0x012C	R/W	Change-Over Temperature Threshold for Cooling (In case temperature is in between both thresholds the last state will be maintained)	0..500 \triangle 0..+50,0 °C 300..1200 \triangle +30,0..+120,0 °F	190/ 660
	301			Reserved		
	302			Reserved		
	303			Reserved		
	304	0x0130	R/W	Valve type selection, heating + cooling 0= ON-OFF ON \triangle Valve Open, OFF \triangle Valve Closed 1=PI Controller PWM 0..100 \triangle 0-100 %PWM 2= OFF-ON OFF \triangle Valve Open, ON \triangle Valve Closed 3= inverted PWM 0 \triangle 100% PWM .. 100% \triangle 0% PWM	0	

Holding Register						
Address		Access	Description	Register value \triangleq Value range	default	
Inputs	336	0x0150	R/W	Configuration external input 1, terminal 11 0 = no function 1 = Occupancy sensor (Open = Occupied) 2 = Occupancy sensor (Closed =Occupied) 3 = Window contact (Open = Window Open) 4 = Window contact (Closed = Window Open) 5 = Disable heating (Open = Heating disabled) 6 = Disable heating (Closed = Heating disabled) 7 = Disable cooling (Open = Disable Cooling) 8 = Disable cooling (Closed = Disable Cooling) 9 = Dew Point Sensor (Open = Dewpoint crossed, disable cooling) 10 = Dew Point Sensor (Closed = Dewpoint crossed, disable cooling)	0	
	337	0x0151	R/W	Configuration external input 2 0 = No function 1 = Occupancy sensor (Open = Occupied) 2= Occupancy sensor (Closed =Occupied) 3 = Window contact (Open = Window Open) 4 = Window contact (Closed = Window Open) 5 = Disable heating (Open = Heating disabled) 6 = Disable heating (Closed = Heating Disabled) 7 = Disable cooling (Open = Disable Cooling) 8 = Disable cooling (Closed = Disable Cooling) 9 = Dew Point Sensor (Open = Dewpoint crossed, disable cooling) 10 = Dew Point Sensor (Closed = Dewpoint crossed, disable cooling)	0	
	338	0x0152	R/W	Configuration Sensor Input 0 = none connected 1 = Change-Over Temp sensor (NTC10K) 2 = Ext. temp sensor (NTC10K) 3 = Temperature limiter	0	
	339	0x0153	R/W	ESI (Energy Savings Input) – ON delay ON delay for ESI. Delays Energy stop by n seconds.	[s]	0
	340	0x0154	R/W	Occupation (OCC-input) – OFF- delay	0...65535 \triangleq 0...65535 [s]	1800

Holding Register (operation to override FC from modbus)						
Address		Access	description	Register value \triangleq Value range	default	
Special	512	0x0200	R/W	Active fan speed setting 0b00000000 = OFF 0b00000001 = Stage low 0b00000010 = Stage medium 0b00000100 = Stage high 0b00001000 = Auto OFF 0b00001001 = Auto low 0b00001010 = Auto medium 0b00001100 = Auto high	0	
	513	0x0201	R/W	setpoint temperature	0..500 \triangleq 0..+50,0 [°C] 300..1200 \triangleq +30..+120,0 [°F]	0
	514	0x0202	R/W	Controller mode Comfort: 0b0000 0000= controller off (<i>Frost protection active</i>) 0b0000 0001= controller auto mode (<i>heating + cooling</i>) 0b0000 0010= controller heating mode only 0b0000 0011= controller cooling mode only 0b0000 0100=ventilating only (<i>PI loop controls fan stages only, valves closed</i>) Controller mode ECO: 0b0001 0000=Regler aus (Frostschutz aktiv) 0b0001 0001=Regler Automatik-Modus (<i>Heizen&Kühlen</i>) 0b0001 0010=Regler NUR Heizen 0b0001 0011=Regler NUR Kühlen 0b0001 0100=NUR Belüftung (<i>PI-Regler steuert die Lüfterstufen, Ventile sind geschlossen</i>)	0	
	515	0x0203	R/W	Active symbols 0x00= show none 0x01= show ECO-leaf 0x02= show dew point 0x04= show frost protect 0x08= show window open 0x10= show attention symbol 0x20= show hourglas 0x40= show lock -symbol 0x80= show ECO-writing	0	

» MOUNTING ADVICE/ DIMENSIONS (MM)

For installing or maintenance, please make sure the power is disconnected. Fix the thermostat base plate to the wall through the four screw holes with distance between axes of 60 mm. Fasten base plate and front cover. Do not press the panel in order to protect LCD.

