

FTK+ (LCD) RS485 Modbus

Duct sensor for humidity and temperature

thermokon[®]
HOME OF SENSOR TECHNOLOGY

Datasheet

Subject to technical alteration
Issue date: 02.11.2023 • A121



» APPLICATION

Duct sensor for measuring humidity and temperature in gaseous media of heating, ventilation and air-conditioning systems. In delivery condition, the sensor is designed for measuring temperature and relative humidity. Alternatively the output can be set to absolute humidity, enthalpy or dew point (depending on the model, changeable via jumper or using Thermokon USEapp). LCD models with RGB background light have a transparent cover. Display configuration and threshold values for color changes can be parameterized via Thermokon USEapp. A mounting flange and fixing material are included in delivery.

» TYPES AVAILABLE

Duct humidity sensor optional with display temperature + humidity – active RS485 Modbus

- FTK+ 140 (LCD) RS485 Modbus incl. MF20
- FTK+ 270 (LCD) RS485 Modbus incl. MF20
- FTK+ 400 (LCD) RS485 Modbus incl. MF20

» SECURITY ADVICE – CAUTION

The installation and assembly of electrical equipment should only be performed by authorized personnel.



The product should only be used for the intended application. Unauthorised modifications are prohibited! The product must not be used in relation with any equipment that in case of a failure may threaten, directly or indirectly, human health or life or result in danger to human beings, animals or assets. Ensure all power is disconnected before installing. Do not connect to live/operating equipment.

Please comply with

- Local laws, health & safety regulations, technical standards and regulations
- Condition of the device at the time of installation, to ensure safe installation
- This data sheet and installation manual

» PRODUCT TESTING AND CERTIFICATION



Declaration of conformity

The declaration of conformity of the products can be found on our website <https://www.thermokon.de/>

» NOTES ON DISPOSAL



As a component of a large-scale fixed installation, Thermokon products are intended to be used permanently as part of a building or a structure at a pre-defined and dedicated location, hence the Waste Electrical and Electronic Act (WEEE) is not applicable. However, most of the products may contain valuable materials that should be recycled and not disposed of as domestic waste. Please note the relevant regulations for local disposal.

» BUILD-UP OF SELF-HEATING BY ELECTRICAL DISSIPATIVE POWER

Sensors with electronic components always have a dissipative power, which affects the temperature measurement of the ambient air. The dissipation in active temperature sensors shows a linear increase with rising operating voltage. This dissipative power has to be considered when measuring temperature. In case of a fixed operating voltage ($\pm 0,2$ V) this is normally done by adding or reducing a constant offset value.

Thermokon transducers can be operated with variable operating voltages. The transducers are set at the factory with a reference operating voltage of 24 V =.

At this voltage, the expected measuring error of the output signal will be the least. Other operating voltages, can cause a measurement deviation changing power loss of the sensor electronics.

A recalibration can be carried out directly on the unit or via a software variable (app or bus).

Remark: Occurring draught leads to a better carrying-off of dissipative power at the sensor. Thus temporally limited fluctuations might occur upon temperature measurement.

» APPLICATION NOTICE FOR HUMIDITY SENSORS

At regular environmental condition, it is recommended to calibrate the sensor annually to check the compliance with the accuracy required in the application. The following conditions can damage the sensor element or lead in long term to loss of the specified accuracy:

- Mechanical stress
- Contamination (e.g. dust / fingerprints)
- Aggressive chemicals
- Ambient conditions (e.g. condensation on measuring element)



Do not touch the sensor elements!

Re-calibration or exchange of the sensor element are not subject of the general warranty.

» TECHNICAL DATA

Measuring values	temperature, humidity (humidity output configurable)	
Output voltage	2x 0..10 V or 0..5 V, min. load 10 k Ω (live-zero configuration via Thermokon USEapp)	
Network technology	RS485 Modbus, RTU, half-duplex, baud rate 9.600, 19.200, 38.400 or 57600, parity: none (2 stopbits), even or odd (1 stopbit), Fail-safe Biasing required	
Power supply	15..35 V = or 19..29 V ~ SELV <i>With alternating voltage, the correct polarity must be ensured</i>	
Power consumption	max. 2,5 W (24 V =) 4,3 VA (24 V ~)	
Measuring range temp.	-20..+80 °C (default setting), optionally configured via Thermokon USEapp	
Measuring range humidity	0..100% rH non-condensing, optionally configured via Thermokon USEapp (enthalpy, absolute humidity, dew point)	
Accuracy temperature	$\pm 0,3$ K (typ. at 21 °C)	
Accuracy humidity	$\pm 2\%$ between 10..90% rH (typ. at 21 °C)	
Air speed	max. 12 m/s	
Display (optional)	LCD 29x35 mm with RGB backlight	
Enclosure	enclosure USE-M, PC, pure white, with removable cable entry, LCD: cover PC, transparent, UV resistant	
Protection	IP65 according to EN 60529	
Cable entry	M25 for cable max. $\varnothing=7$ mm, seal insert for fourfold cable entry	
Connection electrical	Mainboard removable plug-in terminal, max. 2,5 mm ²	Plug-in card removable plug-in terminal, max. 1,5 mm ²
Pipe	PA6, black, $\varnothing=19,5$ mm, length=140 270 400 mm	
Filter	stainless steel wire mesh	
Ambient condition	-20..+70 °C, short term condensation	



When several BUS devices are supplied by one 24 V AC voltage supply, it is to be ensured that all "positive" operating voltage input terminals (+) of the field devices are connected with each other and all "negative" operating voltage input terminals (-) (=reference potential) are connected together (in-phase connection of field devices). In case of reversed polarity at one field device, a supply voltage short-circuit would be caused by that device. The consequential short-circuit current flowing through this field may cause damage to it.

Therefore, pay attention to correct wiring.

» USE ENCLOSURE WITH UV AND WEATHER RESISTANCE

After some time, outdoor mounted plastics can lose their color and quality. Therefore, all USE housings are made of special white polycarbonate (PC). The light-stable colorants and additives are used to achieve optimum protection of the polymer while maintaining color stability. The titanium dioxide used is specially developed for polycarbonate and offers excellent UV protection through the reflection of the entire light spectrum including the UV component by 340 nm. This effectively counteracts the otherwise occurring photochemical polymer degradation. The colors stay full for a long time without fading. The material is also resistant to cold and frost.

» CONFIGURATION



The Thermokon bluetooth dongle with micro-USB is required for communication between USEapp and USE-M / USE L (Item No.: 668262). Commercial bluetooth dongles are not compatible.



Application-specific reconfiguration of the devices can be carried out using the Thermokon USEapp. The configuration is carried out in the voltage-supplied state.



The configuration-app and the app description can be found in the Google Play Store or in the Apple App Store.

» APPLICATION NOTICE

The Bluetooth dongle snaps into the socket easily. When removing, please fix the plug-in card (option PCB) so that it is not unintentionally pulled out.



After a certain time, dirt in the air can collect on the filter and then adversely affect the operation of the sensor. Under normal ambient condition an annual maintenance is recommended. Rinse the filter after cleaning with distilled water and dry it using clean oil-free air or nitrogen. Extremely contaminated filters should be replaced. At extreme ambient conditions, e.g. corrosive gases, the humidity sensor may have to be changed.

» MOUNTING ADVICES

The sensor can be mounted on the ventilation duct by means of the mounting flange MF20 TPO (optional with mounting base).

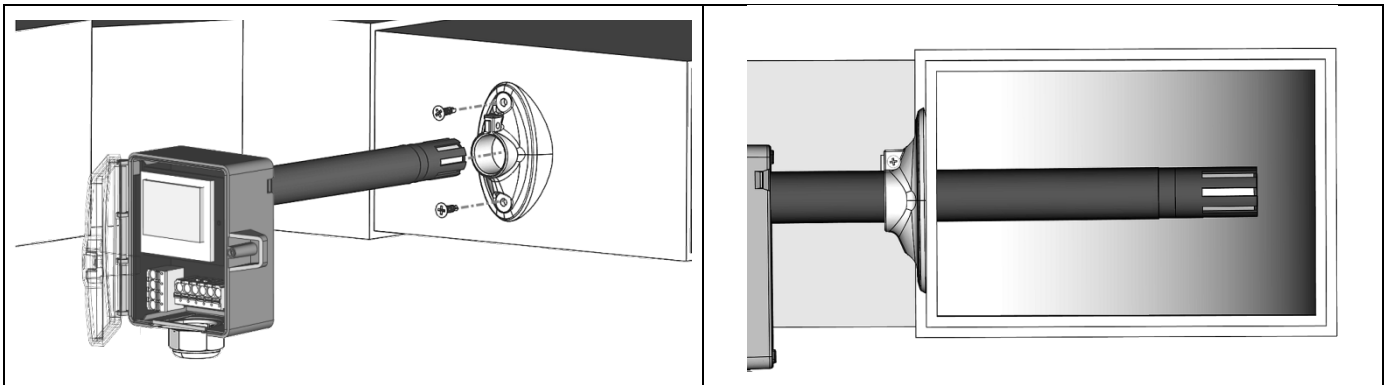

optional:

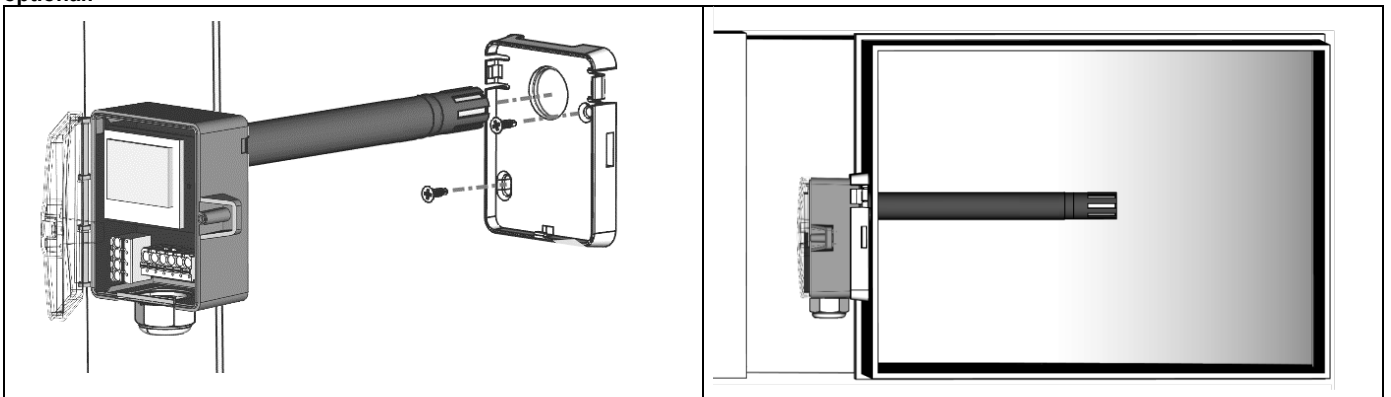

» CONNECTION PLAN

To change the output voltage range (default 0..10 V to 0..5 V) via jumper, the display must be removed from the board first.

FTK+ (LCD) RS485

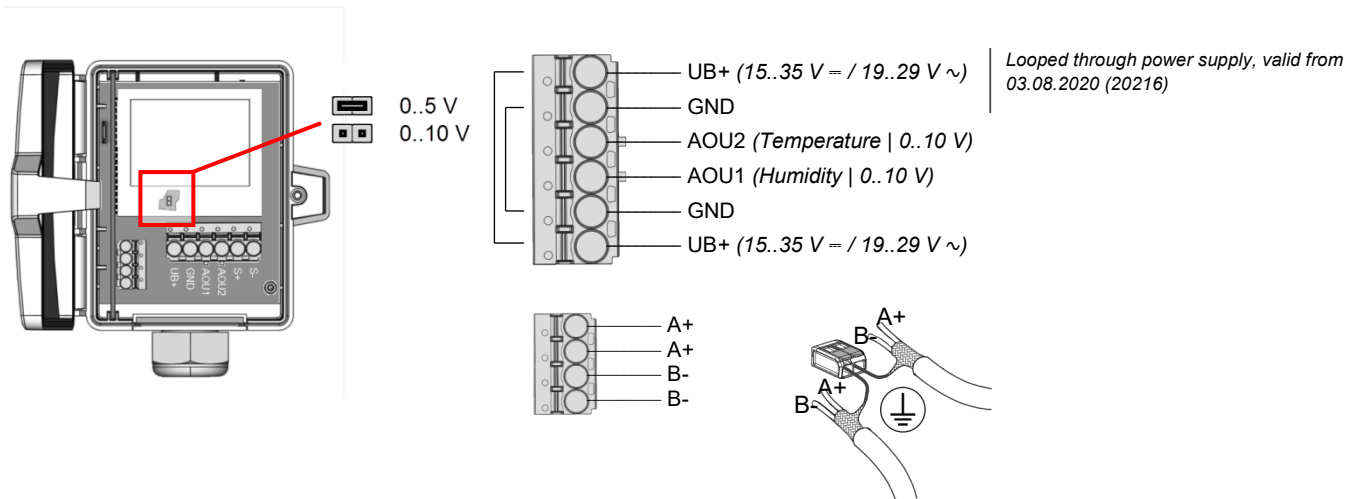

» DIP SWITCHES, PLUG-IN CARD

The Modbus address of the device is set in the range of 1 ... 31 (binary encoded) using a 5-pole DIP switch. With address 0 via DIP, an extended address range (32..247) is available via USEapp.

* factory default settings

Termination 120 Ω	
<input type="checkbox"/> ON	<input type="checkbox"/> ON
Not active*	active

Baud			
<input type="checkbox"/> ON	<input type="checkbox"/> ON	<input type="checkbox"/> ON	<input type="checkbox"/> ON
2 3	2 3	2 3	2 3
9600*	19200		
<input type="checkbox"/> ON	<input type="checkbox"/> ON	<input type="checkbox"/> ON	<input type="checkbox"/> ON
2 3	2 3	2 3	2 3
38400	57600		

Modbus address				
<input type="checkbox"/> ON	<input type="checkbox"/> ON	<input type="checkbox"/> ON	<input type="checkbox"/> ON	<input type="checkbox"/> ON
1 2 3 4 5	1 2 3 4 5	1 2 3 4 5	1 2 3 4 5	1 2 3 4 5
ON=2 ⁰ (1)*	ON=2 ¹ (2)	ON=2 ² (4)	ON=2 ³ (8)	ON=2 ⁴ (16)

Sample address: 26 ON

Parity			
<input type="checkbox"/> ON	<input type="checkbox"/> ON	<input type="checkbox"/> ON	<input type="checkbox"/> ON
4 5	4 5	4 5	4 5
none*	even	odd	none
(2-stopbits)	(1-stopbit)	(1-stopbit)	(1-stopbit)

Address	Access	Description	Resolution / Unit
1	R	relative humidity	0.1 %rF

Adress	Access	Description	Resolution / Unit					
			Register 400= 1		Register 400= 2			
0	R	Temperature	SI	0.1	°C	Imperial	0.1	°F
2	R	Absolute humidity	SI	0.01	g/m ³	Imperial	0.01	Gr/ft ³
3	R	Enthalpy	SI	0.1	kJ/kg	Imperial	0.1	BTU/lb
4	R	Dew point	SI	0.1	°C	Imperial	0.1	°F

Available measured values are type-dependent.



Modbus addresses:

USE-RS485 Modbus Interface

A detailed description of the Modbus addresses can be found under the following link: → [Download](#)

» DIMENSIONS (MM)

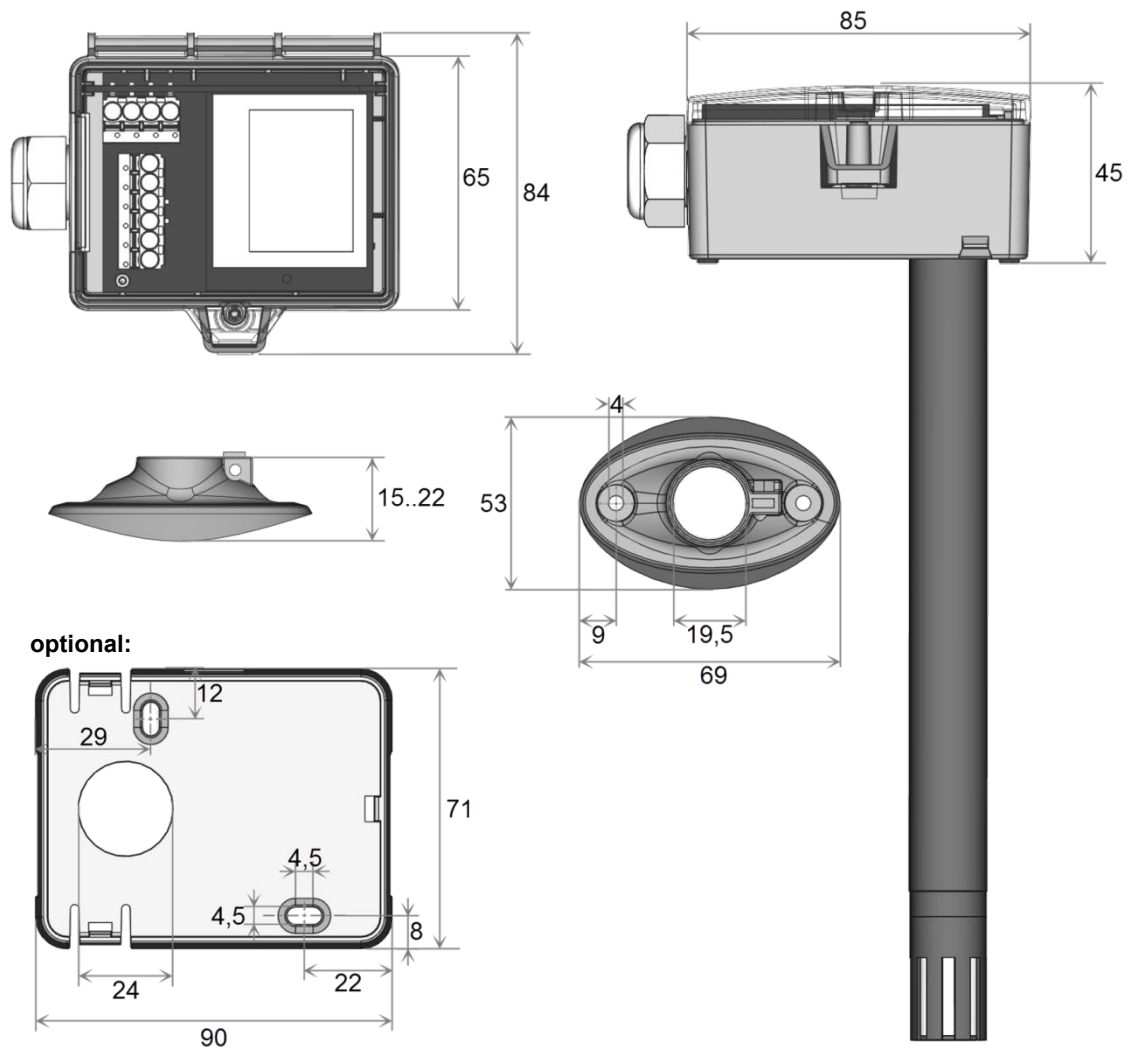

» ACCESSORIES (INCLUDED IN DELIVERY)

Mounting flange MF20 TPO

Item No. 612562

Mounting kit universal

Item No. 698511

• Cover screw + screw cover • 2 Rawlplugs • 2 Screws (countersunk head) • 2 Screws (rounded head)

» ACCESSORIES (OPTIONAL)

Bluetooth-Dongle

Item No. 668262

Mounting base

Item No. 631228

Filter stainless steel, wire mesh

Item No. 231169

RS485 Biasing Adapter

Item No. 811378

USB RS485 Modbus RTU Logger

Item No. 809917

USB Interface RS485 (incl. driver CD)

Item No. 668293