

NOVOS 3 Temp | Temp_rH

Room temperature sensor with optional humidity

thermokon[®]
HOME OF SENSOR TECHNOLOGY

Datasheet

Subject to technical alteration
Issue date: 03.11.2022 • A123

novos



With design cover (left), standard design w/o design cover (right)

» APPLICATION

Room sensor for recording room temperature. The maintenance-free sensor creates the conditions for a pleasant indoor climate and well-being. Typical applications are schools, office buildings, hotels, cinemas or similar.

» TYPES AVAILABLE

Room sensor temperature – active V 0..10 V | A 4..20 mA

- NOVOS 3 Temp TRV
- NOVOS 3 Temp TRA

Room sensor temperature + humidity – active VV 0..10 V | AA 4..20 mA

- NOVOS 3 Temp_rH VV
- NOVOS 3 Temp_rH AA

Optional: additional passive temperatur sensor (type VVS / AAS)
i.e.: Pt1000 / NI1000 / NTC10k

» SECURITY ADVICE – CAUTION

The installation and assembly of electrical equipment should only be performed by authorized personnel.



The product should only be used for the intended application. Unauthorised modifications are prohibited! The product must not be used in relation with any equipment that in case of a failure may threaten, directly or indirectly, human health or life or result in danger to human beings, animals or assets. Ensure all power is disconnected before installing. Do not connect to live/operating equipment.

Please comply with

- Local laws, health & safety regulations, technical standards and regulations
- Condition of the device at the time of installation, to ensure safe installation
- This data sheet and installation manual

» MOUNTING ADVISE ROOM SENSORS

The Accuracy of the room sensors are influenced by the technical specifications as well as the positioning and the installation type.

During Assembly:

- Seal mounting box (if present).
- Installation type, air draught, heat source, radiation heat or direct sunlight can affect the measurement.
- Bulding material specific properties of the installation place (*brick-, concrete-, partition wall, cavity wall, ...*) can affect the measurement. (e.g.: *Concrete accepts room temperature variation slower than cavity walls*)

Assembly not recommendet in...

- Air draught (e.g.: close to windows / doors / fans ...)
- Near heating sources,
- Direct sunlight
- Niches / between furniture / ...

» BUILD-UP OF SELF-HEATING BY ELECTRICAL DISSIPATIVE POWER

Sensors with electronic components always have a dissipative power, which affects the temperature measurement of the ambient air. The dissipation in active temperature sensors shows a linear increase with rising operating voltage. This dissipative power has to be considered when measuring temperature. In case of a fixed operating voltage ($\pm 0,2$ V) this is normally done by adding or reducing a constant offset value.

Thermokon transducers can be operated with variable operating voltages. The transducers are set at the factory with a reference operating voltage of 24 V =.

At this voltage, the expected measuring error of the output signal will be the least. Other operating voltages, can cause a measurement deviation changing power loss of the sensor electronics.

A recalibration can be carried out directly on the unit or via a software variable (app or bus).

Remark: Occurring draught leads to a better carrying-off of dissipative power at the sensor. Thus temporally limited fluctuations might occur upon temperature measurement.

» APPLICATION NOTICE FOR HUMIDITY SENSORS

At regular environmental condition, it is recommended to calibrate the sensor annually to check the compliance with the accuracy required in the application. The following conditions can damage the sensor element or lead in long term to loss of the specified accuracy:

- Mechanical stress
- Contamination (e.g. dust / fingerprints)
- Aggressive chemicals
- Ambient conditions (e.g. condensation on measuring element)



Do not touch the sensor elements!

Re-calibration or exchange of the sensor element are not subject of the general warranty.

» PRODUCT TESTING AND CERTIFICATION



Declaration of conformity

The declaration of conformity of the products can be found on our website <https://www.thermokon.de/>

» NOTES ON DISPOSAL



As a component of a large-scale fixed installation, Thermokon products are intended to be used permanently as part of a building or a structure at a pre-defined and dedicated location, hence the Waste Electrical and Electronic Act (WEEE) is not applicable. However, most of the products may contain valuable materials that should be recycled and not disposed of as domestic waste. Please note the relevant regulations for local disposal.

» TECHNICAL DATA



Measuring values (type-dependent)	temperature, humidity			
Output voltage (type-dependent)	TRV VV VVS 1x/2x 0..10 V or 0..5 V, min load 10 kΩ (live-zero configuration 1..10/2..10 V) configurable via Thermokon NOVOSapp			
Output Amp (type-dependent)	TRA AA AAS 1x/2x 4..20 mA, max. load 500 Ω			
Output passive (type dependent)	VVS AAS PT1000 / NI1000 / NTC10K			
Power supply (type-dependent)	TRV VV VVS 15..35 V = or 19..29 V ~ SELV		TRA AA AAS 15..35 V = SELV	
Power consumption (type-dependent)	TRV VV VVS typ. 0,4 W (24 V =) 0,8 VA (24 V ~)		TRA AA AAS max. 0,5 W / 24 V =	
Measuring range humidity (type-dependent)	relative humidity (default) 0..100% rH	Enthalpy 0..85 KJ/kg	absolute humidity 0..50 0..80 g/m³,	dew point 0..+50 -20..+80 °C,
	optional configurable via Thermokon NOVOSapp			
Output signal range temp. (type-dependent)	Analogue outputs (scaling analogue output) 0..+50 °C (default setting), selectable from 4 temperature ranges -50..+50 0..+50 -15..+35 -20..+80 °C configurable via NOVOSapp		passive sensor depending on sensor	
Accuracy temperature (type dependent)	Analogue outputs ±0,5K (typ. at 21 °C)		passive sensor depending on sensor	
Accuracy humidity (type-dependent)	±2% between 10..90% rH (typ. at 21 °C)			
Enclosure	PC V0, pure white, design cover (optional)			
Protection	IP20 according to DIN EN 60529			
Cable entry	rear entry, breaking points bottom, drill mark top			
Connection electrical	tool-free mountable spring terminal, max. 1,5 mm²			
Ambient condition	-35..+70 °C, max. 85% non-condensing			
Mounting	surface mounted on flush-mounting box (Ø=60 mm) or to be mounted flat onto the surface using screws, base part can be mounted and wired separately			
Notes	configurable via NOVOSapp			

* Devices with power supply are subject to self heating which is processed by the internal electronics. An offset is added before outputting a measuring value. The measurement principle of passive sensors does not allow an internal processing. The measured value of a passive sensor differs from the output signal of an active device, if both are mounted in the same device.



» CONNECTION PLAN

The following connection diagrams show the assignment of measuring values to analog outputs in factory default. Output variables reconfigurable via Thermokon NOVOSapp.

Room sensor temperature – active TRV 0..10 V | TRA 4..20 mA

NOVOS 3 Temp TRV MultiRange	NOVOS 3 Temp TRA MultiRange
 <ul style="list-style-type: none"> —AOU1— Temperature 0..10 V —GND— 0 V ⊥ —UB+— 15..35 V = oder 19..29 V ~ 	 <ul style="list-style-type: none"> —AOI1— Temperature 4..20 mA —UB+— 15..35 V =

Room sensor temperature + humidity – active VV 0..10 V | AA 4..20 mA

NOVOS 3 Temp_rH VV MultiRange	NOVOS 3 Temp_rH AA MultiRange
 <ul style="list-style-type: none"> —AOU2— Temperature 0..10 V —AOU1— Humidity 0..10 V —GND— ⊥ —UB+— 15..35 V = or 19..29 V ~ 	 <ul style="list-style-type: none"> —AOI2— Temperature 4..20 mA —AOI1— Humidity 4..20 mA —UB+— 15..35 V =

AA design: To use only the temperature output, connect AOI1 and use the NOVOS app to configure AOI1 as temperature output. Alternatively connect the GND of the analogue input terminal to AOI1.

» MOUNTING ADVICES

De-energize the device before installation.

The installation can be performed on the flat wall surface or on a flush-mounted box. A representative place should be selected. Sunshine and draft, e.g. in the installation tube should be avoided, so that the measurement result is not falsified. Seal the end of the installation tube.

- For wiring, the upper part of the device must be removed from the base plate. Base plate and upper part are detachably connected to each other by means of locking lugs.
- The mounting of the base plate on the flat wall surface is done with rawplugs and screws.
- Finally, the device is attached to the base plate and fixed with the screw.

Housing open / close

Snap the upper part of the housing into the locking lug on the upper side

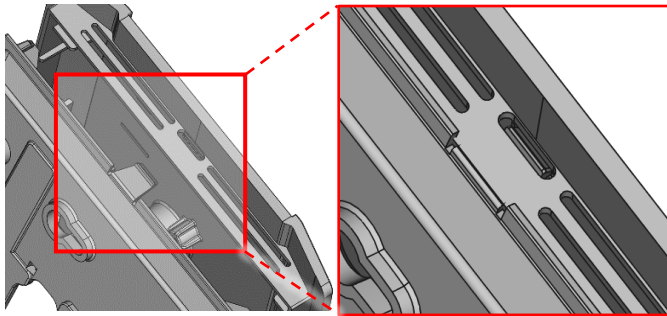

Fix the upper part of the housing on the underside with the screw

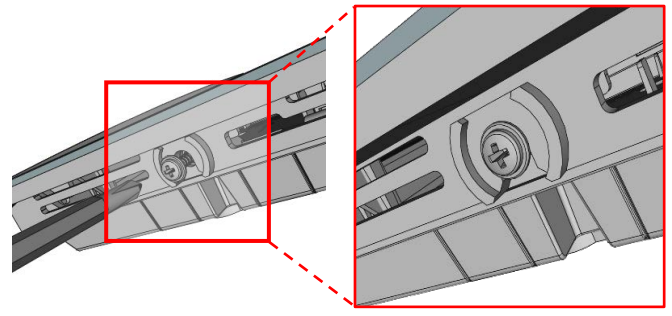

Cable entry

There are predetermined breaking points for 2 optional cable entries on the underside of the base plate

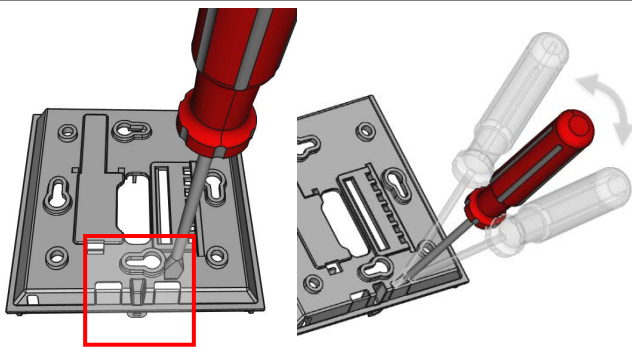

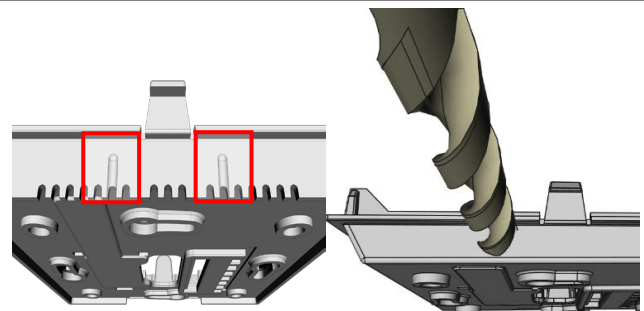

On the upper side of the base plate there are 2 grits as position for a drill hole max. Ø 6 mm



When using a drill, you should absolutely ensure that the base plate is firmly clamped. Before drilling, the pressure must be reduced and carefully drilled. A sudden break-through of the drill bit can be the result.

» CONFIGURATION

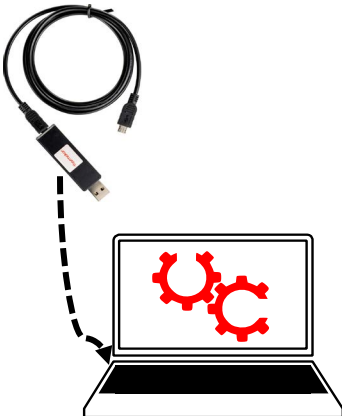
The configuration is performed in powered state. The following options are available for configuring the device:

Device connection	Micro-USB	Micro-USB
Configuration adapter	<p>Thermokon USB-Interface</p> 	<p>USB-Bluetooth Dongle</p> 
Configuration interface	<p>PC/Notebook with uConfig software</p> <p>Parameterization partial via desktop PC/Notebook with uConfig software, via Thermokon USB-Interface*. Item No. 597838</p>	<p>Smartphone/Tablet with NOVOs App</p> <p>Parameterization with mobile devices via Bluetooth and NOVOsApp. A separately available Bluetooth dongle* is required. Item no. 668262</p>

*Commercially available Bluetooth dongles or USB to Micro-USB adapter cables are not compatible. You need a mobile device that supports at least Bluetooth version 4.1. The configuration app with the corresponding instructions can be downloaded from the Google Play Store or the Apple App Store.

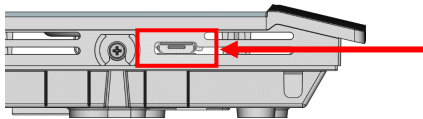

Position of the micro USB port, see bottom of the device, for configuration with Bluetooth dongle or Micro-USB programming interface

» DIMENSIONS (MM)

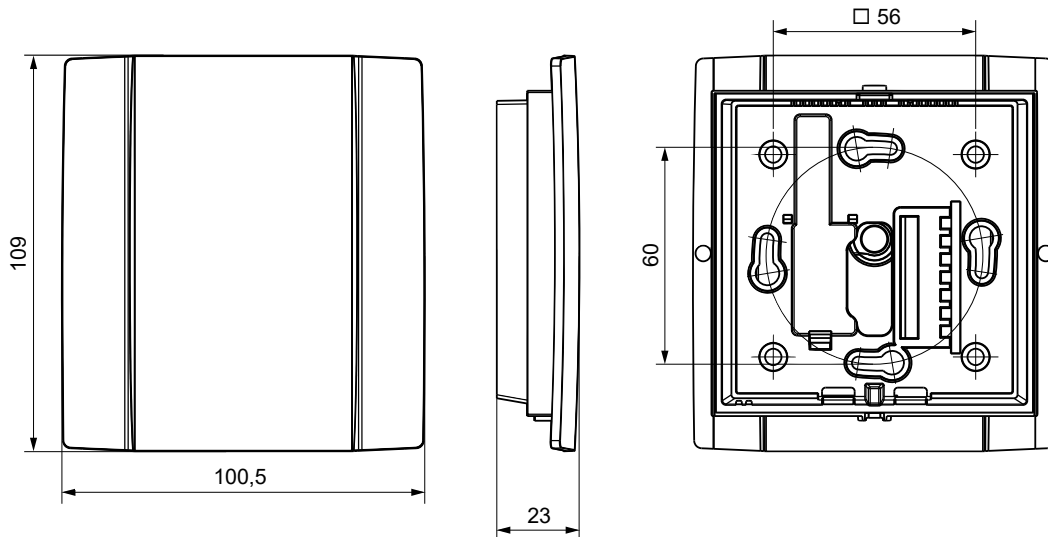

» ACCESSORIES (OPTIONAL)

Rawplugs and screws (2 pcs. each)	Item No. 102209
PSU-UP24 – flush mount power supply 24 V (AC Input: 100..240 V ~ DC Output 24 V = 0,5 A)	Item No. 645737
Bluetooth dongle	Item No. 668262
Thermokon USB-Interface	Item No. 597838
Mounting bracket (surface mounted) white	Item No. 795050
Mounting bracket (surface mounted) black	Item No. 795074