

TFR_e

Frost protection thermostat

thermokon[®]
HOME OF SENSOR TECHNOLOGY

Datasheet

Subject to technical alteration
Issue date: 16.02.2024 • A120



» APPLICATION

Electronic frost protection thermostat for downstream temperature monitoring of water air heaters in ventilation and air-conditioning systems to prevent frost damages. With P-controller for continuous override of the heat exchanger valve in the limit range. Safety shutdown of the fan and, if necessary, closing the air inlet flaps to protect the heat exchanger in case of alarm. Temperature detection optionally with contact sensor, immersion sensor or cable sensor with compression fitting with four selectable sensor characteristic curves.

» SECURITY ADVICE – CAUTION

The installation and assembly of electrical equipment should only be performed by authorized personnel.



The product should only be used for the intended application. Unauthorised modifications are prohibited! The product must not be used in relation with any equipment that in case of a failure may threaten, directly or indirectly, human health or life or result in danger to human beings, animals or assets. Ensure all power is disconnected before installing. Do not connect to live/operating equipment.

Please comply with

- Local laws, health & safety regulations, technical standards and regulations
- Condition of the device at the time of installation, to ensure safe installation
- This data sheet and installation manual

» PRODUCT TESTING AND CERTIFICATION



Declaration of conformity

The declaration of conformity of the products are available on our website
<https://www.thermokon.de/direct/en-gb/products/tfre>

» NOTES ON DISPOSAL



The crossed-out wheeled bin symbol indicates that the product or removable batteries must not be disposed of with household or commercial waste. Within the EU, you are legally obliged to dispose of the product separately and appropriately in accordance with the national laws of your country. Alternatively, please contact your supplier or Thermokon Sensortechnik GmbH. Further information can be found at: www.thermokon.com

» TECHNICAL DATA

Measuring values	temperature		
Output voltage	Temp OUT temperature value 0..10 V, (0..+100 °C), max. load 10 mA	Valve OUT valve control signal 0..10 V, (0..100%), max. load 10 mA	
Output switch contact	FAN relay floating contact NO for 250 V ~, max. load 6 A	Alarm relay floating contact NO for 30 V ~ / =, max. load 1 A	
Power supply	13,5..35 V = or 24 V ~ (±10%) SELV		
Power consumption	max. 2 VA (24 V~)		
Measuring temperature	0..+100 °C		
Accuracy temperature	±1 K (typ. at 0 °C)		
Sensor	configurable, Pt1000 (default), Ni1000, Ni1000TK5 NTC10K		
Inputs	Sensor IN input for Sensor Pt1000 (default), NTC10K, Ni1000, Ni1000TK5	Controller IN specification of controller output	FAN IN input for floating contact
Functions	P controller, frost protection alarm set point 0..+16 °C (Hysteresis 0..+ 3 °K configurable), internal controller for valve actuation (Valve OUT). Start point limitation 0.. +3 K configurable		
Display	LED green indicator valve OUT	LED red Alarm	LED yellow FAN
Enclosure	ABS, white		
Protection	IP20 according to EN 60529		
Connection electrical	removable plug-in terminal, max. 2,5 mm ²		
Ambient condition	-40..+70 °C max. 85% rH non-condensing		
Mounting	prepared for mounting on DIN rail TS35 (35x7,5 mm) according to EN 60715		

» APPLICATION

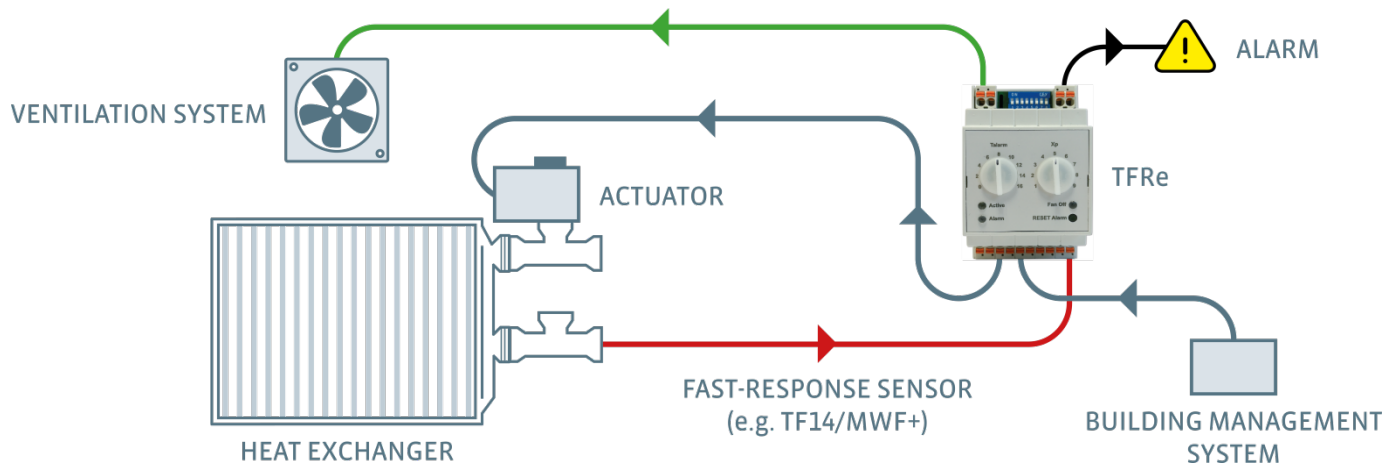

» CONNECTION PLAN

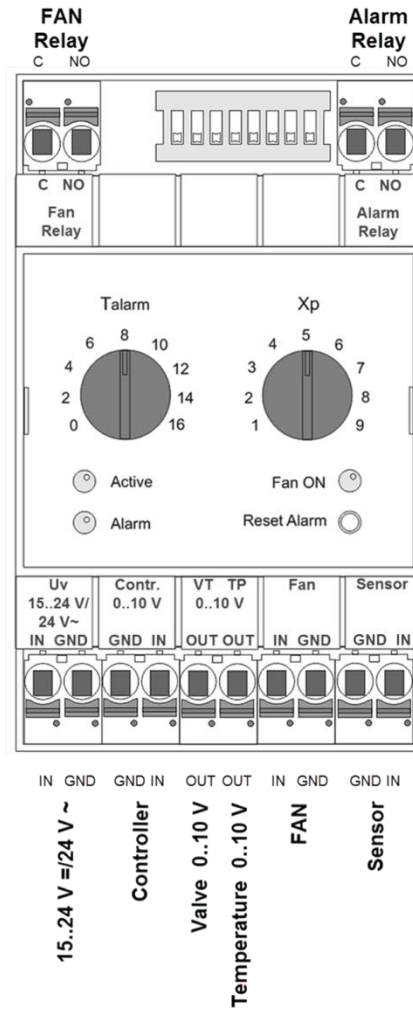

» FUNCTION DESCRIPTION

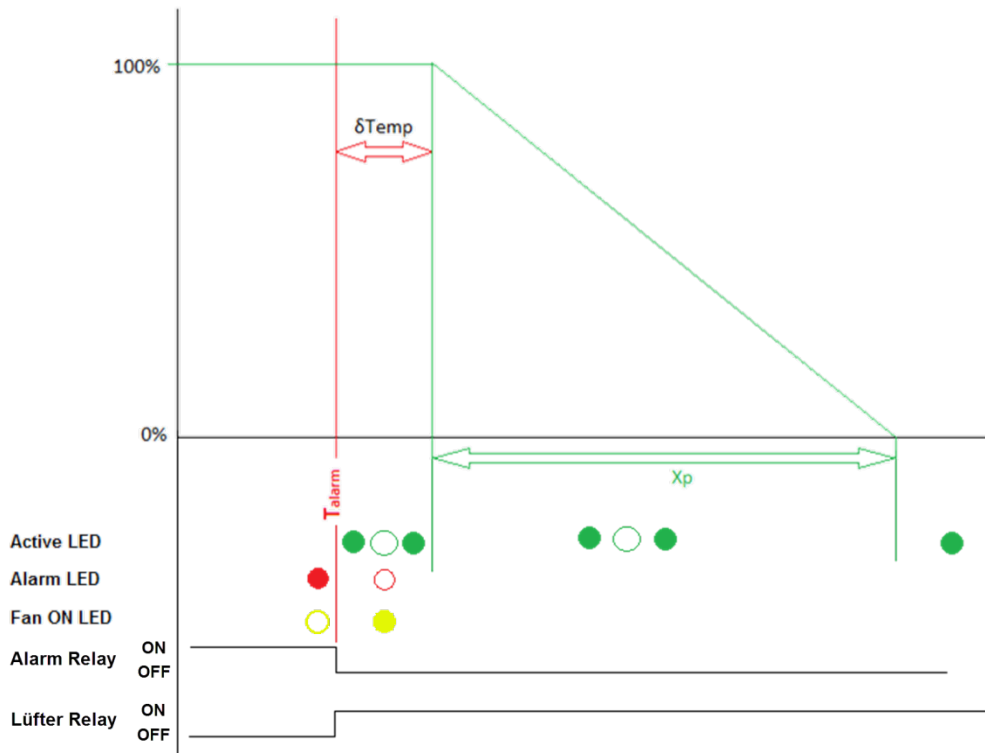

Commisioning

With applied voltage and if the temperature is above the adjusted proportional band, the green "Active" LED starts to light up as shown in the function diagram.

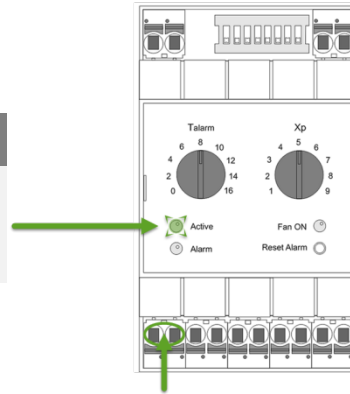

Power supply

Fan ON

Fan control

If there is no alarm the fan relay is energized.

The yellow "FAN ON" LED visualizes the state of the fan input.

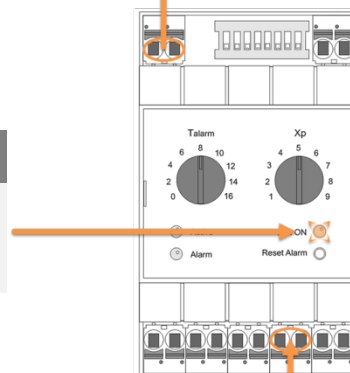

Fan ON

Connection passive sensor

The return temperature of the heat exchanger for the control loop is measured with a connected passive sensor (i.e., TF14) at the sensor input (sensor_IN) and is output again with 0..10 V at the temperature output (temperature_Out).

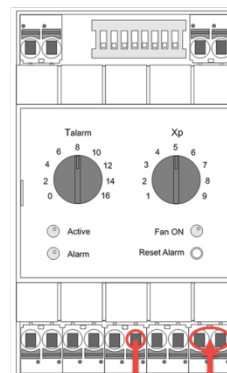

0..10 V

Temperature

Digital Input (FAN_IN)

The digital input (Lüfter_IN) signals the electronic frost protection thermostat that the fan coil is in operation. If the fan coil is switched off, the yellow LED goes off. As a result, the setpoint specification of the controller is ignored and the return temperature of the heat exchanger is regulated to the set setpoint (DIP 7 & 8) with the internal P controller. A flashing yellow LED indicates that the anti-panic thermostat is in the alarm state and the fan has been switched off.

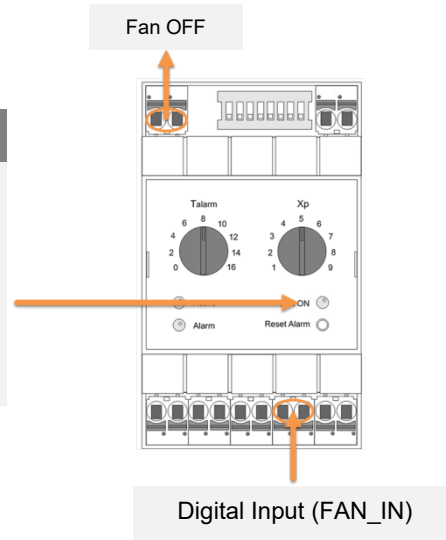

Temperature monitoring

If the return temperature of the heat exchanger remains higher than the set proportional range, the manipulated variable specified by the controller is looped through the analog input (controller) unchanged to the analog output (valve_OUT). The 0..10 V actuating variable output signal can be inverted via the DIP switch (DIP 3).

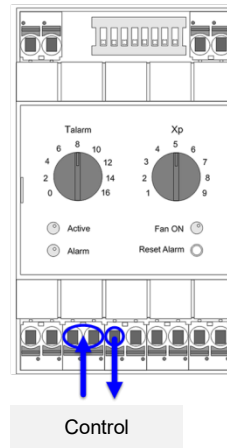

Control

If the temperature falls into the proportional range xp (see figure), the manipulated variable increases proportionally by the corresponding percentage of the p-band and increases the flow of the valve. If the return temperature is within the proportional range, this is indicated by a flashing green LED. If the temperature drops below the set alarm setpoint, the red LED lights, the corresponding alarm relay (NO) turns on and the fan is switched off. The yellow LED flashes during this state. The return valve is opened completely (manipulated variable 100 %). If the temperature returns to the range of the P band when the automatic reset (DIP 8) is set, the alarm is automatically switched off, the red LED goes off and the regulation is continued. If an alarm triggers 3 times within 2 hours, a manual reset via button is necessary. If a manual reset is set, each alarm triggered must be acknowledged by hand on the device.

If the temperature returns to the range of the P band when the manual reset (DIP 8) is set, the alarm and the red LED stays on and the regulation is continued. The fan relay remains off.

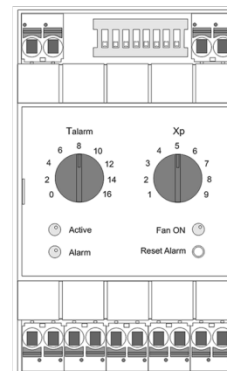

Control

If the sensor monitoring detects a temperature >105 ° C or a sensor failure (eg due to cable break or short circuit), an alarm is triggered and the control value 100% (10 V) is output at the valve.

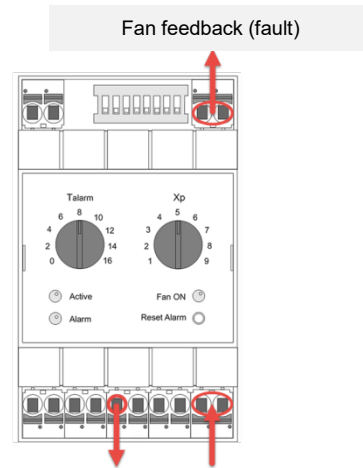

Control variable 100% (10 V)

Passive sensor (fault)

» CONFIGURATION

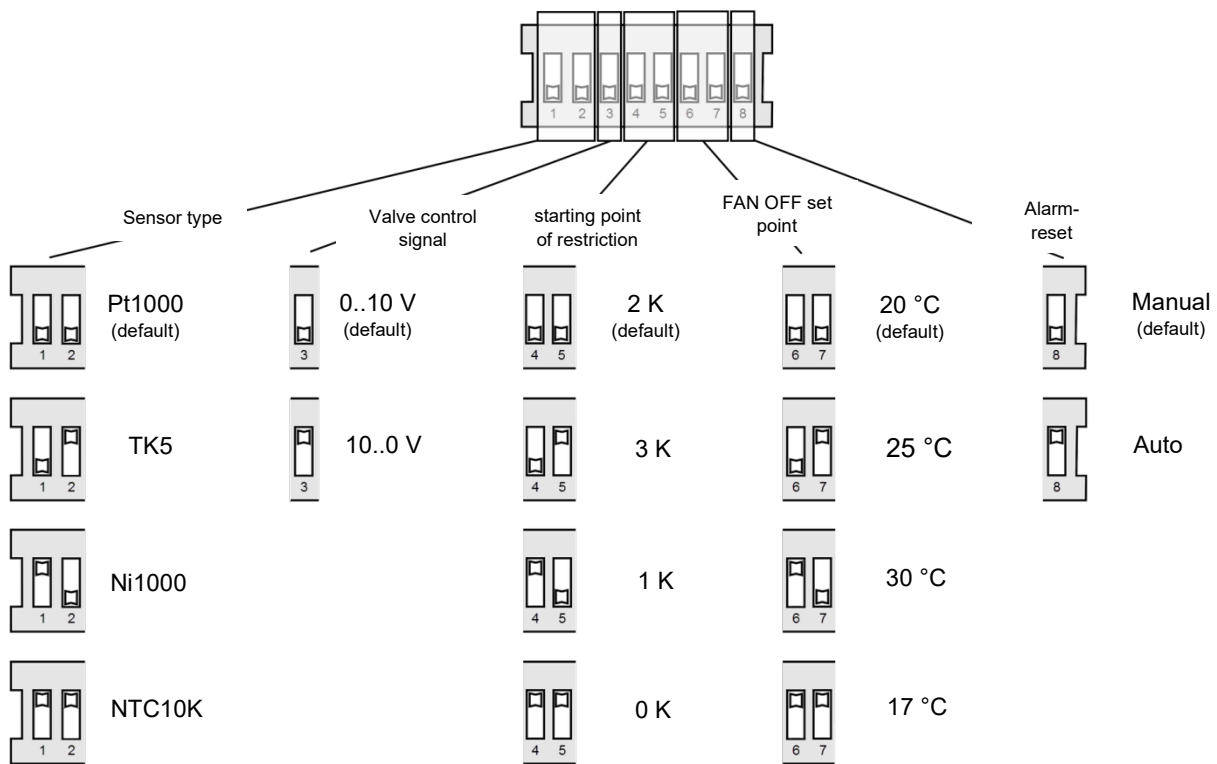

» DIMENSIONS (MM)

