

» WRF06 AQ RS485 BACnet

Combined sensor CO₂ / VOC / Temperature / rel. Humidity

thermokon[®]
HOME OF SENSOR TECHNOLOGY

Datasheet

Subject to technical alteration
Issue date: 17.08.2020 • A110



» APPLICATION

Flush mounting sensor for detection of CO₂, temperature (optional) and relative humidity (optional) in room and office spaces. Fits into switch frames 55x55 mm. For direct connection to a DDC or a monitoring system, using 0..10 V outputs. Also available with traffic light LED.

» TYPES AVAILABLE

Room sensor CO₂ + temperature (opt.) + relative humidity (opt.) – active BUS

WRF06 CO₂ RS485 BACnet MS/TP
WRF06 CO₂ Temp RS485 BACnet MS/TP
WRF06 CO₂ Temp_rH RS485 BACnet MS/TP

Room sensor VOC + CO₂ (opt.) + temperature (opt.) + relative humidity (opt.) – active BUS

WRF06 CO₂+VOC RS485 BACnet MS/TP
WRF06 VOC Temp RS485 BACnet MS/TP
WRF06 CO₂+VOC Temp_rH RS485 BACnet MS/TP

» SECURITY ADVICE – CAUTION



The installation and assembly of electrical equipment should only be performed by authorized personnel.

The product should only be used for the intended application. Unauthorised modifications are prohibited! The product must not be used in relation with any equipment that in case of a failure may threaten, directly or indirectly, human health or life or result in danger to human beings, animals or assets. Ensure all power is disconnected before installing. Do not connect to live/operating equipment.

Please comply with

- Local laws, health & safety regulations, technical standards and regulations
- Condition of the device at the time of installation, to ensure safe installation
- This data sheet and installation manual

» NOTES ON DISPOSAL



As a component of a large-scale fixed installation, Thermokon products are intended to be used permanently as part of a building or a structure at a pre-defined and dedicated location, hence the Waste Electrical and Electronic Act (WEEE) is not applicable. However, most of the products may contain valuable materials that should be recycled and not disposed of as domestic waste. Please note the relevant regulations for local disposal.

» GENERAL REMARKS CONCERNING SENSORS

Especially with regard to passive sensors in 2-wire conductor versions, the wire resistance of the supply wire has to be considered. If necessary the wire resistance has to be compensated by the follow-up electronics. Due to self-heating, the wire current affects the measurement accuracy, so it should not exceed 1 mA.

When using lengthy connection wires (depending on the cross section used) the measuring result might be falsified due to a voltage drop at the common GND-wire (caused by the voltage current and the line resistance). In this case, 2 GND-wires must be wired to the sensor - one for supply voltage and one for the measuring current.

Sensing devices with a transducer should always be operated in the middle of the measuring range to avoid deviations at the measuring end points. The ambient temperature of the transducer electronics should be kept constant. The transducers must be operated at a constant supply voltage ($\pm 0,2$ V). When switching the supply voltage on/off, onsite power surges must be avoided.

» REMARKS TO ROOM SENSORS

Location and Accuracy of Room Sensors

The room sensor should be mounted in a suitable location for measuring accurate room temperature. The accuracy of the temperature measurement also depends directly on the temperature dynamics of the wall. It is important, that the back plate is completely flush to the wall so that there is sufficient circulation of air through the vents in the cover, otherwise, deviations in temperature measurement will occur due to uncontrolled air circulation. The temperature sensor should not be covered by furniture or other objects. Mounting next to doors (due to draught) or windows (due to colder outside wall) should be avoided.

Surface and Flush Mounting

The measuring result is influenced by the thermal characteristics of the wall. A solid concrete wall responds to thermal fluctuations within a room in a much slower than a light-weight structure wall. Room temperature sensors installed in flush-mounted boxes have a longer response time to thermal variations. In extreme cases they detect the radiant heat of the wall even if the air temperature in the room is lower for example. The quicker the dynamics of the wall (temperature acceptance of the wall) or the longer the selected inquiry interval of the temperature sensor is the smaller the deviations limited in time are.

» BUILD-UP OF SELF-HEATING BY ELECTRICAL DISSIPATIVE POWER

Temperature sensors with electronic components always have a dissipative power, which affects the temperature measurement of the ambient air. The dissipation in active temperature sensors shows a linear increase with rising operating voltage. This dissipative power has to be considered when measuring temperature. In case of a fixed operating voltage ($\pm 0,2$ V) this is normally done by adding or reducing a constant offset value. As Thermokon transducers work with a variable operating voltage, only one operating voltage can be taken into consideration, for reasons of production engineering. Transducers 0..10 V / 4..20 mA have a standard setting at an operating voltage of 24 V =. That means, that at this voltage, the expected measuring error of the output signal will be the least. For other operating voltages, the offset error will be increased by a changing power loss of the sensor electronics. If a re-calibration should become necessary later directly on the sensor, this can be done with sensors with BUS interface via an appropriate software variable.

Remark: Occurring draft leads to a better carrying-off of dissipative power at the sensor. Thus temporally limited fluctuations might occur upon temperature measurement.

» APPLICATION NOTICE FOR HUMIDITY SENSORS

Refrain from touching the sensitive humidity sensor/element. Touching the sensitive surface will void warranty.

For standard environmental conditions re-calibration is recommended once a year to maintain the specified accuracy. This is possible via a corresponding software variable.

When exposed to high ambient temperature and/or high levels of humidity or presence of aggressive gases (i.e. chlorine, ozone, ammonia) the sensor element may be affected and re-calibration may be required sooner than specified. Re-calibration and deterioration of the humidity sensor due to environmental conditions are not subject of the general warranty.

» INFORMATION ABOUT INDOOR AIR QUALITY CO₂

EN 13779 defines several classes for indoor air quality:

Category	CO ₂ content above the content in outdoor air in ppm		Description
	Typical range	Standard value	
IDA1	<400 ppm	350 ppm	Good indoor air quality
IDA2	400.. 600 ppm	500 ppm	Standard indoor air quality
IDA3	600..1.000 ppm	800 ppm	Moderate indoor air quality
IDA4	>1.000 ppm	1.200 ppm	Poor indoor air quality

» INFORMATION ABOUT SELF-CALIBRATION FEATURE CO₂

Virtually all gas sensors are subject to some sort of drift. The degree of drift is partially dependent on the use of quality components and good design. But even with good components and excellent design, a small amount of drift can still occur in the sensor that may ultimately result in the need for a sensor to be recalibrated.

The natural drift of the sensor is caused by:

- Dust/dirt • Aggressive chemicals absorbed inside chamber / optical elements • Corrosion inside chamber (high rh, condensation) • Temperature cycles causing mechanical stress • Electron/hole migration in the photo detector's semiconductor • Drift of photo amplifiers • External mechanical stress on chamber • Light source wear-off

Most of the effects listed above will be compensated by the automatic self-calibration of the sensor's dual channel technology. In contrast to commonly used ABC-Logic self-calibrating sensors with dual channel technology are suitable for all applications including those operating 24 hours, 7 days a week, for example hospitals.

However some effects cannot be compensated automatically and may result in a very gradual natural drift of a few ppm per month. This natural drift is not covered by Thermokon's 5-year warranty.

» APPLICATION NOTICE FOR AIR QUALITY SENSORS VOC

Unlike CO₂ sensors, which specifically measure CO₂, mixed gas sensors detect a wide range of gases. The sensor signal does not indicate the type of gas or its concentration in ppm. Mixed gas sensors detect gases and vapours consisting of carbohydrates, or more generally gases that can be oxidised (burnt): Odours, perfume, cleaning fluid scent, tobacco smoke, new materials fumigations (furniture, carpets, paint, glue ...).

Unlike CO₂, which humans cannot sense, the amount of odours (VOC) indicates the level of air quality. VOC sensors have proven their value in a multitude of applications for many years.

Measuring principle:

Similar to a catalyst converter the organic molecules are burnt (oxidized) when in contact with the sensor's heated -dioxide surface, adding a small amount of heat combustion. The increased temperature is measured providing a signal proportional to the number of molecules being burnt. CO₂ cannot be detected as it cannot be further oxidized.

Refrain from touching the sensor's element sensitive surface. Touching the sensitive surface element will void warranty.

» INFORMATION ABOUT CALIBRATION VOC

Similar to a catalyst converter the VOC sensor will deteriorate over time, which will affect the sensitivity. This VOC sensor automatically compensates the decrease in sensitivity by dynamic auto-calibration.

The reference level of air quality is derived from the ambient conditions over a 72h period. The lowest reading within this 72h time period will be used as reference level, representing the "clean and fresh air level".

» PRODUCT TESTING AND CERTIFICATION



Declaration of conformity

The declaration of conformity of the products can be found on our website <https://www.thermokon.de/>.

» **TECHNICAL DATA**

Measuring values	CO ₂ , VOC, temperature + humidity (depending on the device)
Network technology	RS485 BACnet MS/TP
Power supply*	15..35 V = or 19..29 V ~ SELV
Power consumption	max. 1,6 W (24 V = 3,9 VA (24 V =)
Enclosure	PC, pure white brilliant, pure white matt, aluminium, anthracite
Protection	IP30 according to EN 60529
Connection electrical	terminal block max. 1,5mm ²
Ambient condition	0..+50 °C, max. 85% rH non-condensing
Notes	optional with traffic light function "TLF", please specify frame design when ordering

Temperature	type-dependent
Measuring range temp	0..+50 °C
Accuracy temperature	±0,5K (typ. at 21 °C)

Humidity	type-dependent				
Measuring range humidity	<table border="1"> <tr> <td>relative humidity 0..100% rH</td> <td>absolute humidity 0..83 g/m³</td> <td>Enthalpy 0..274 KJ/kg</td> <td>dew point -110..+50 °C</td> </tr> </table>	relative humidity 0..100% rH	absolute humidity 0..83 g/m ³	Enthalpy 0..274 KJ/kg	dew point -110..+50 °C
relative humidity 0..100% rH	absolute humidity 0..83 g/m ³	Enthalpy 0..274 KJ/kg	dew point -110..+50 °C		
Accuracy humidity	±2% between 10..90% rH (typ. at 21 °C)				

CO ₂	type-dependent
Measuring range CO ₂	0..5000 ppm
Accuracy CO ₂	±50 ppm +3 % of reading (typ. at 21 °C, 50% rH)
Calibration	Self-calibration, Dual Channel
Sensor	NDIR (non-dispersive, infrared)
Display (optional)	3 LEDs indicating air quality (traffic light function 'TLF'), (optional)

VOC	type-dependent
Measuring range VOC	0..100 %
Calibration	Self-calibration
Sensor	VOC sensor (heated metal oxide semiconductor)

*Power supply

When several BUS devices are supplied by one 24 V AC voltage supply, it is to be ensured that all "positive" operating voltage input terminals (+) of the field devices are connected with each other and all "negative" operating voltage input terminals (-) (=reference potential) are connected together (in-phase connection of field devices).

In case of reversed polarity at one field device, a supply voltage short-circuit would be caused by that device. The consequential short-circuit current flowing through this field may cause damage to it.

Therefore, pay attention to correct wiring.

» **BACNET INTERFACE**

BACnet Objects, PICS and BIBBs:
RS485 BACnet interface

A detailed description of the BACnet interface can be found at the following link:
→ [Download](#)

» **CONNECTION PLAN**

The BACnet address of the device is set binary coded in the range of 1 ... 127 via 7 dip-switches. (the address 0 is reserved and cannot be selected).

DIP switch block

DIP 1	DIP 2	DIP 3	DIP 4	DIP 5	DIP 6	DIP 7	Address (binary coded)
2 ⁰ (1)	2 ¹ (2)	2 ² (4)	2 ³ (8)	2 ⁴ (16)	2 ⁵ (32)	2 ⁶ (64)	
ON	OFF	OFF	OFF	OFF	OFF	OFF	1 (default)
OFF	ON	OFF	OFF	OFF	OFF	OFF	2
...							
ON	ON	ON	ON	ON	ON	ON	127

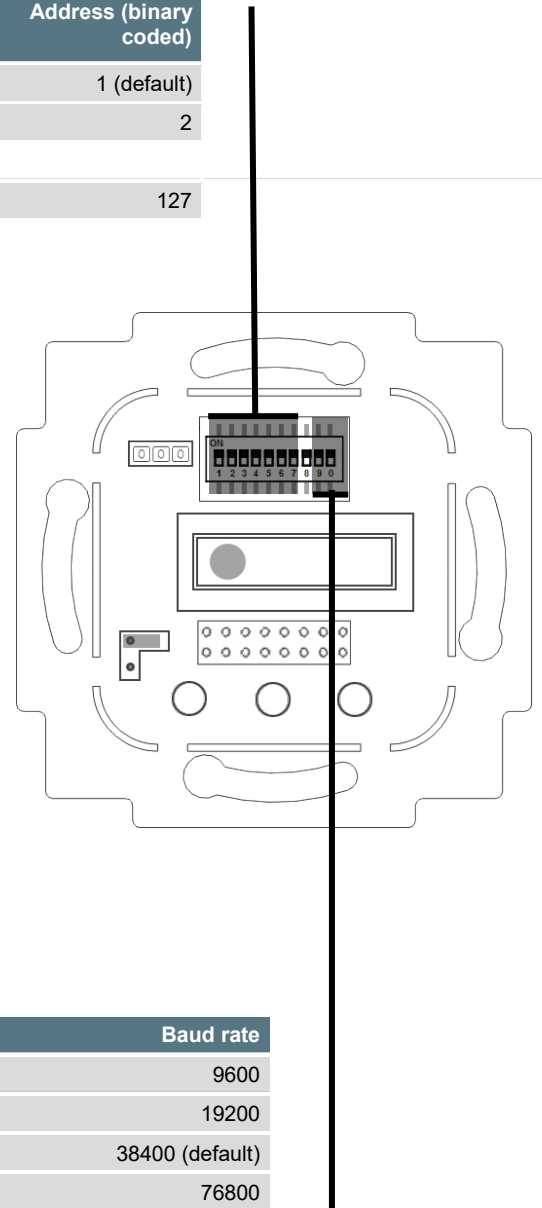
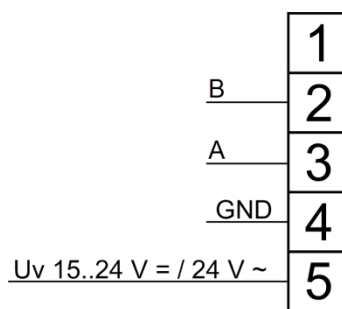

Jumper	Termination 120 Ohm
	inactive (default)
	active

DIP 9	DIP 0	Baud rate
OFF	OFF	9600
ON	OFF	19200
OFF	ON	38400 (default)
ON	ON	76800

DIP 8 has no function (reserved).

» **FUNCTION DESCRIPTION**

The room operating panel has 3 LEDs for the indication of different status for verifying device functions and bus communication.

- **Green LED** Operating voltage
- **Orange LED** lights up upon receipt of a flawless telegram which was addressed to the device.
- **Red LED** lights up upon receipt of a telegram, which was addressed to another device.

If telegrams are sent from the Master and no LEDs are flashing at the operating unit, the communication properties must be verified.

» **OPTIONAL TLF (TRAFFIC LIGHT FUNCTION)**

The thresholds are default values and can be changed via a BACnet object.

- 0..750 ppm – green LED
- 751..1250 ppm – yellow LED
- 1251..2000 ppm – red LED

» MOUNTING ADVICES

The device is designed for mounting on a flush box. The bus cable is connected to the device by a terminal screw. For pre-wiring, the terminal screw can be drawn from the device.

Due to the extended retaining capacity for the cabling, the use of deep installation boxes is recommended. Installation must be made on representative places for the measurement value logging to avoid a falsification of the measuring result. Solar radiation and draught should be avoided. The end of the installation tube in the flush box must be sealed to avoid any draught in the tube falsifying the measuring result.

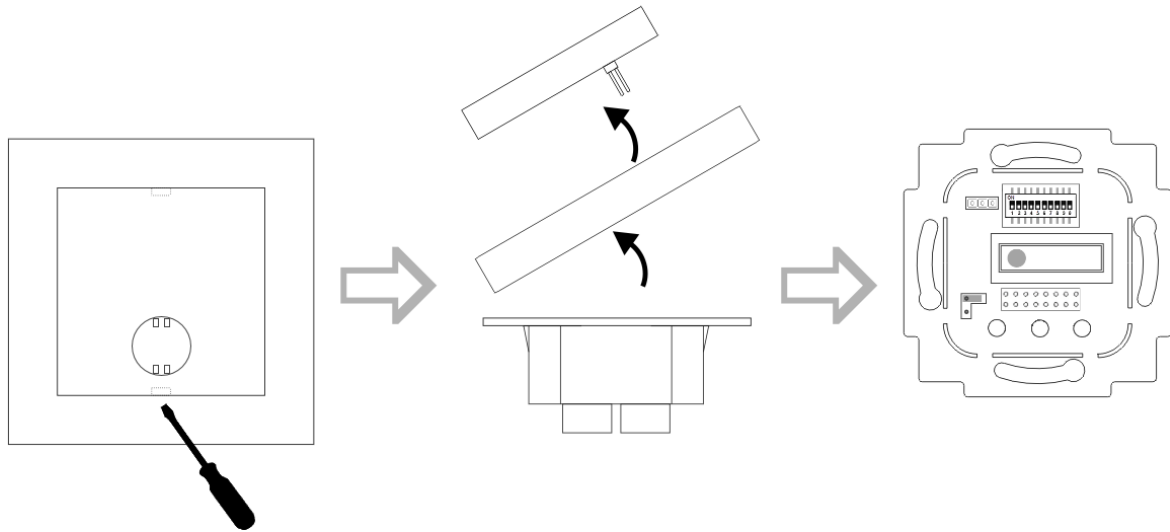

» DIMENSIONS (MM)

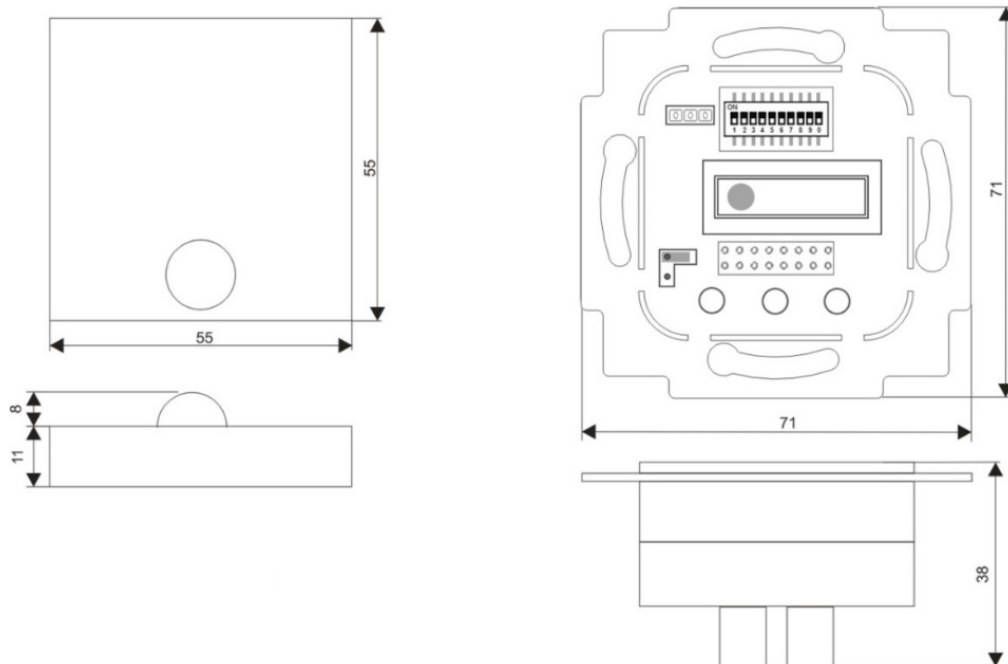

» ACCESSORIES (OPTIONAL)

Raw plugs and screws (2 pcs. each)

Item No.: 102209