

SR65 TF 902 MHz

Wireless Cable Temperature Sensor

thermokon[®]
HOME OF SENSOR TECHNOLOGY

Datasheet

Subject to technical alteration
Issue date: 16/08/2024 • A140



» APPLICATION

Self-powered wireless EnOcean duct sensor to measure the temperature in gaseous media of heating, ventilation and air-conditioning systems. Configuration via airConfig.

» SECURITY ADVICE – CAUTION

The installation and assembly of electrical equipment should only be performed by authorized personnel.



The product should only be used for the intended application. Unauthorised modifications are prohibited! The product must not be used in relation with any equipment that in case of a failure may threaten, directly or indirectly, human health or life or result in danger to human beings, animals or assets. Ensure all power is disconnected before installing. Do not connect to live/operating equipment.

Please comply with

- Local laws, health & safety regulations, technical standards and regulations
- Condition of the device at the time of installation, to ensure safe installation
- This data sheet and installation manual

» PRODUCT TESTING AND CERTIFICATION



Declaration of conformity

The declaration of conformity of the products are available on our website
<https://www.thermokon.de/direct/en-gb/categories/sr65-tf>

» NOTES ON DISPOSAL



The crossed-out wheeled bin symbol indicates that the product or removable batteries must not be disposed of with household or commercial waste. Within the EU, you are legally obliged to dispose of the product separately and appropriately in accordance with the national laws of your country. Alternatively, please contact your supplier or Thermokon Sensortechnik GmbH. Further information can be found at: www.thermokon.com

» GUIDELINES FOR DEVICES WITH SOLAR ENERGY STORAGE

Due to the energy-optimized EnOcean radio technology used in "EasySens" wireless sensors, the devices can work without batteries and self-charge themselves using electric energy generated by integrated solar cells. This makes the devices almost maintenance free and environmentally sound due to not having to replace batteries.

For optimum use, the device should be mounted in a location with sufficient ambient brightness. Minimum illumination of 200 lx (artificial light or ambient) is required for at least 3 to 4 hours each day. (The health and safety regulations at work require a minimum illumination of 500 lx for office workplaces).

The solar cell should be mounted facing towards the window direction if possible. If the device has a temperature sensor, then even periodic direct sun radiation should be avoided due to incorrect false temperature readings.

The mounting position should be selected so that the device will not be obstructed in the future: for example by placement areas, additional furniture or roll-fronted cupboards.

The sensor is supplied in an operational state. If the sensor has been stored in darkness for longer periods, the internal solar energy storage will most likely need to be recharged. This would normally happen automatically during commissioning or during initial start up in ambient light. If the initial charge is not sufficient, the sensor will reach its full operating state up to 3 to 4 days, if the requirements for minimum illumination per day are met. The sensor will then transmit continuously in darkness as specified f (2/3 days on factory default telegram timing). Depending on the application it is also possible for the devices to operate in darker rooms (with brightness <100 lx) by using the battery back-up option. Batteries to be used are listed in accessories.

The operating time when using batteries will depend on the transmission frequency as well as the component aging and the self-discharge of the battery. Standard operating time will be 5-10 years on factory default telegram timing. Changing of the device from solar to battery operation is done automatically by simply adding a battery to the device.

» INFORMATION ABOUT EASYSSENS® (RADIO) / AIRCONFIG GENERAL USAGE



EasySens® - airConfig

Basic information about EasySens® radio and about general usage of our airConfig software, please download from our website.

» OVERVIEW OF THE RADIO TELEGRAMS



EEP

The structure of the data contained in the telegram can be found in the EEP (EnOcean equipment profile) list provided by the EnOcean Alliance.

» TECHNICAL DATA

Measuring values	temperature
Radio technology	EnOcean (IEC 14543-3-10), transmission power <10 mW
Frequency	902 MHz, optional 315 MHz
Power supply	solar cell, internal super cap, optional: battery LS14250
Measuring range temp	-4..+140 °F, Configured via airConfig
Working range temperature	-39..+266 °F
Accuracy temperature	±1% of measuring range (typ. at 69.8 °F)
Transmission interval	configured via airConfig, Default: Wake-up time =100 sec. Heartbeat cycle = 10x
Enclosure	PA6, color pure white, upper housing material PC, transparent, quick lock screws
Protection	IP65 according to EN 60529
Pocket	Stainless steel 1.4571, Ø=0.24 in., L=1.97 in
Ambient condition	-13..+149 °F, max. 85% rH, short term condensation
Notes	integrated battery backup possibility for usage in dark rooms, additional probe lengths on request

» MOUNTING ADVICES

Mounted with the cable entry pointing downwards.

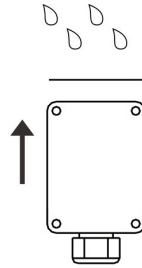

» CONFIGURATION WITH AIRCONFIG

No airConfig is needed if default settings will be used. airConfig and a EnOcean USB transceiver (i.e. USB300C) will be mandatory if the default EEP and other settings shall be changed.

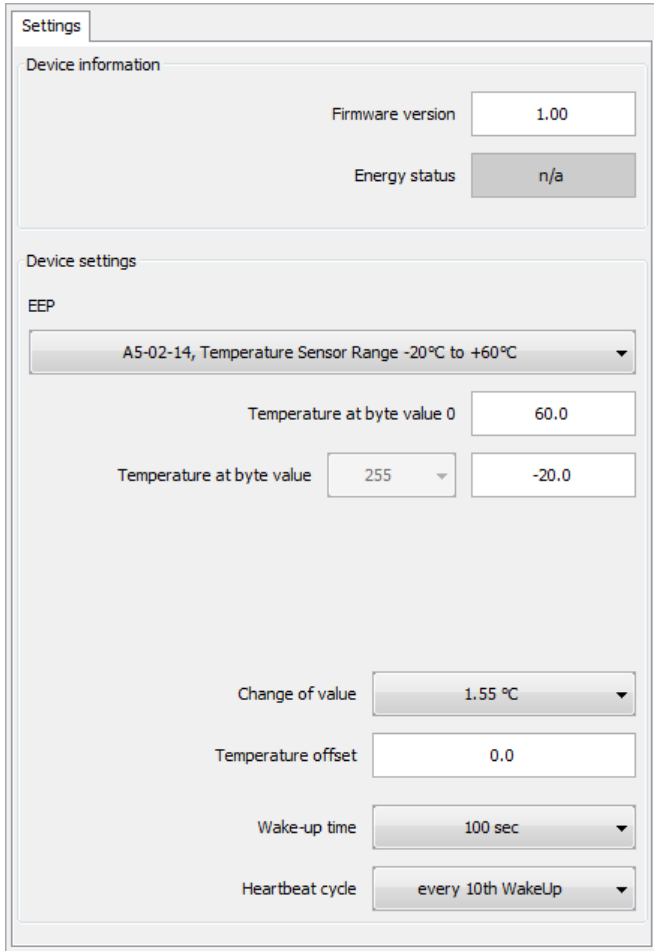

On the top there are some informations like the **Firmware version** and the **Energy status** of the device.

It is necessary to ensure that the device is full charged or a battery is inserted. The Energy status must be  to configure the device.

Clicking on the drop-down menu **EEP** to choose the desired measuring range. The corresponding **Byte values** of the Temperature values are shown below.



Attention: Only operate the sensor in the specified temperature range.

Change of value defines the minimal temperature change required since the last transmission to send a new telegram.

Set **Temperature offset** for individual adjustment.

The **Wake-up** time defines the measuring interval.

Heartbeat cycle defines the maximal number of Wake-ups without transmitting the temperature between 2 transmissions. Receivers monitor this interval to detect missing sensor signals.

Right-click on the device icon and send configuration to initiate the transfer of the new settings.

As the sensor will be sleeping it will need to be woken up by pressing the LRN button. Once the configuration has been transferred successfully into the device the sensor will be highlighted in green.

Highlighted in red indicates a problem during the transmission.

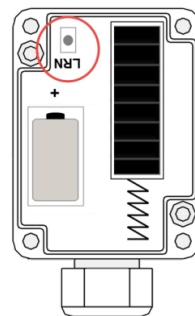

Note:

The more frequently a device is programmed to wake up, measure and send data, the more energy is being consumed, which can lead to insufficient energy charge of the sensor by ambient illumination.

» OVERVIEW OF AIRCONFIG SELECTABLE RADIO TELEGRAMS

A5-02-14 (default)					
A5-02-01	A5-02-02	A5-02-03	A5-02-04	A5-02-05	A5-02-06
A5-02-07	A5-02-08	A5-02-09	A5-02-0A	A5-02-0B	A5-02-10
A5-02-11	A5-02-12	A5-02-13	A5-02-15	A5-02-16	A5-02-17
A5-02-18	A5-02-19	A5-02-1A	A5-02-1B	A5-02-20	A5-02-30

» DIMENSIONS (IN.)

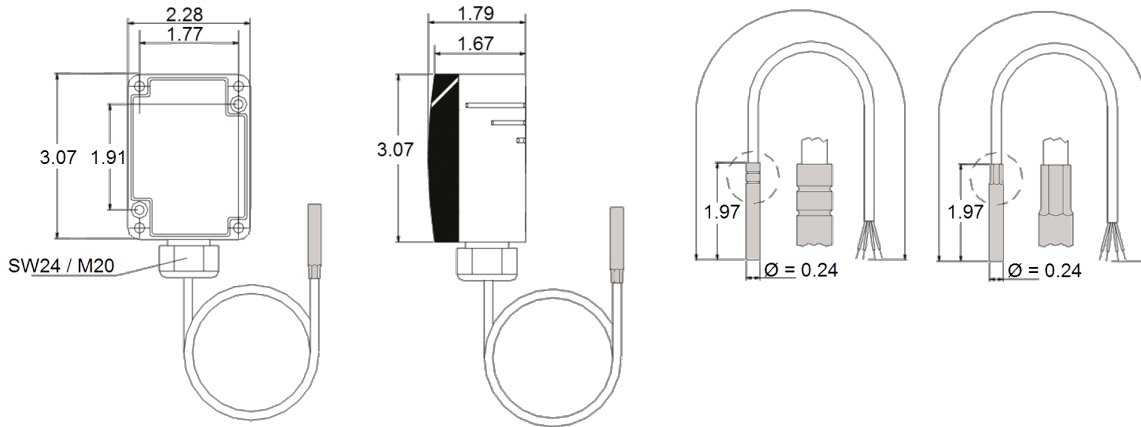

» OPTIONAL ACCESSORIES

Battery LS14250
 Mounting flange (MF6)
 Compression fittings G 1/4", $\varnothing=0.24$ in. (KL6VA)
 Immersion pocket, mat. brass nickel-plated, safe up to 16 bar
 Immersion pocket, mat. stainless steel, safe up to 40 bar

Item No. 315098
 Item No. 102407
 Item No. 103213
 THMSDS
 THVADS