

LA+ CO2+VOC (LCD) (Temp_rH) RS485 BACnet

Outdoor sensor for air quality, optional temperature and humidity

thermokon[®]
HOME OF SENSOR TECHNOLOGY

Datasheet

Subject to technical alteration
Issue date: 16.02.2023 • A125

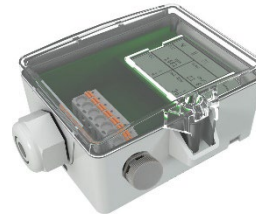

LA+ CO2+VOC



LA+ CO2+VOC Temp



LA+ CO2+VOC Temp_rH

The following illustrations show the version with LCD

» APPLICATION

Air quality sensor for measuring VOC air quality, CO₂, temperature and humidity in outdoor areas with 2.0..10 V output. LCD models with RGB background light have a transparent cover.

» TYPES AVAILABLE

Outdoor sensor CO₂ + VOC, optional with display – active RS485 BACnet MS/TP

- LA+ CO₂+VOC (LCD) RS485 BACnet

Outdoor sensor CO₂ + VOC + temp, optional with display – active RS485 BACnet MS/TP

- LA+ CO₂+VOC (LCD) Temp RS485 BACnet

Outdoor sensor CO₂ + VOC + temp + rH, optional with display – active RS485 BACnet MS/TP

- LA+ CO₂+VOC (LCD) Temp_rH RS485 BACnet

» SECURITY ADVICE – CAUTION

The installation and assembly of electrical equipment should only be performed by authorized personnel.



The product should only be used for the intended application. Unauthorised modifications are prohibited! The product must not be used in relation with any equipment that in case of a failure may threaten, directly or indirectly, human health or life or result in danger to human beings, animals or assets. Ensure all power is disconnected before installing. Do not connect to live/operating equipment.

Please comply with

- Local laws, health & safety regulations, technical standards and regulations
- Condition of the device at the time of installation, to ensure safe installation
- This data sheet and installation manual

» PRODUCT TESTING AND CERTIFICATION



Declaration of conformity

The declaration of conformity of the products are available on our website <https://www.thermokon.de/>.

» NOTES ON DISPOSAL



As a component of a large-scale fixed installation, Thermokon products are intended to be used permanently as part of a building or a structure at a pre-defined and dedicated location, hence the Waste Electrical and Electronic Act (WEEE) is not applicable. However, most of the products may contain valuable materials that should be recycled and not disposed of as domestic waste. Please note the relevant regulations for local disposal.

» GENERAL REMARKS CONCERNING SENSORS

Especially with regard to passive sensors in 2-wire conductor versions, the wire resistance of the supply wire has to be considered. If necessary the wire resistance has to be compensated by the follow-up electronics. Due to self-heating, the wire current affects the measurement accuracy, so it should not exceed 1 mA.

When using lengthy connection wires (depending on the cross section used) the measuring result might be falsified due to a voltage drop at the common GND-wire (caused by the voltage current and the line resistance). In this case, 2 GND-wires must be wired to the sensor - one for supply voltage and one for the measuring current.

Sensing devices with a transducer should always be operated in the middle of the measuring range to avoid deviations at the measuring end points. The ambient temperature of the transducer electronics should be kept constant. The transducers must be operated at a constant supply voltage ($\pm 0,2$ V). When switching the supply voltage on/off, onsite power surges must be avoided.

» BUILD-UP OF SELF-HEATING BY ELECTRICAL DISSIPATIVE POWER

Sensors with electronic components always have a dissipative power, which affects the temperature measurement of the ambient air. The dissipation in active temperature sensors shows a linear increase with rising operating voltage. This dissipative power has to be considered when measuring temperature. In case of a fixed operating voltage ($\pm 0,2$ V) this is normally done by adding or reducing a constant offset value.

Thermokon transducers can be operated with variable operating voltages. The transducers are set at the factory with a reference operating voltage of 24 V =.

At this voltage, the expected measuring error of the output signal will be the least. Other operating voltages, can cause a measurement deviation changing power loss of the sensor electronics.

A recalibration can be carried out directly on the unit or via a software variable (app or bus).

Remark: Occurring draught leads to a better carrying-off of dissipative power at the sensor. Thus temporally limited fluctuations might occur upon temperature measurement.

» APPLICATION NOTICE FOR HUMIDITY SENSORS

At regular environmental condition, it is recommended to calibrate the sensor annually to check the compliance with the accuracy required in the application. The following conditions can damage the sensor element or lead in long term to loss of the specified accuracy:

- Mechanical stress
- Contamination (e.g. dust / fingerprints)
- Aggressive chemicals
- Ambient conditions (e.g. condensation on measuring element)



Do not touch the sensor elements!

Re-calibration or exchange of the sensor element are not subject of the general warranty.

» INFORMATION ABOUT INDOOR AIR QUALITY CO₂

EN 13779 defines several classes for indoor air quality:

Category	CO ₂ content above the content in outdoor air in ppm		Description
	Typical range	Standard value	
IDA1	<400 ppm	350 ppm	Good indoor air quality
IDA2	400.. 600 ppm	500 ppm	Standard indoor air quality
IDA3	600..1.000 ppm	800 ppm	Moderate indoor air quality
IDA4	>1.000 ppm	1.200 ppm	Poor indoor air quality

» INFORMATION ABOUT SELF-CALIBRATION FEATURE CO₂

All gas sensors are subject to drift. The degree of drift is dependent on the use of components and product design. In addition, the following environmental conditions, among others, can accelerate/ favor the aging and wear of the sensors:

- Mechanical stress (also due to temperature fluctuation)
- Contamination (dust / fingerprints e.g.)
- Abrasive chemicals
- Environmental influences (high humidity / condensation on measuring element)

An internal self calibration function with dual channel technology compensates the caused drift. Thermokon sensors are for permanent use. (e.g. hospitals).

» APPLICATION NOTICE FOR AIR QUALITY SENSORS VOC

Volatile organic compounds (VOC) are gaseous and vaporous substances of organic origin in the air. VOC-sensors monitor the significant part of humanly olfactory sensed air quality. (e.g. body odour | tobacco smoke | odour of materials, furniture, carpets, paint, adhesives, ...)

The VOC-Value is an application-specific indication for air quality and doesn't provide any information about individual components of VOC

A VOC sensor oxidises the organic molecules that collide with it, which results in changing the resistance of the semiconductor.

Any contact with the sensitive sensors must be avoided and will invalidate the warranty.

The VOC Sensor is factory calibrated and can be calibrated via NOVOSapp subsequently, if needed.

» TECHNICAL DATA

Measuring values <i>(type-dependent)</i>	CO ₂ , VOC, temperature and humidity	
Output voltage	2x 0..10 V or 0..5 V, min. load 10 kΩ (live-zero configuration via Thermokon USEapp)	
Network technology	RS485 BACnet MS/TP, Fail-safe Biasing required	
Power supply	15..35 V = or 19..29 V ~ SELV <i>With alternating voltage, the correct polarity must be ensured</i>	
Power consumption	max. 2,3 W (24 V =) max. 4,3 VA (24 V ~)	
Measuring range temp. <i>(type-dependent)</i>	Temp Temp_rH 0..+50 °C (default setting) , optionally configured via Thermokon USEapp	
Measuring range humidity <i>(type-dependent)</i>	Temp_rH 0..100% rH non-condensing, optionally (enthalpy, absolute humidity, dew point)	
Measuring range CO ₂	0..2000 ppm (default), 0..5000 ppm (optionally configured via Thermokon USEapp)	
Accuracy temperature <i>(type-dependent)</i>	Temp Temp_rH ±0,5 K (typ. at 21 °C)	
Accuracy humidity <i>(type-dependent)</i>	Temp_rH ±2% between 10..90% rH (typ. at 21 °C)	
Accuracy CO ₂	±50 ppm +3% of reading (typ. at 21 °C, 50% rH)	
Calibration	self-calibration, Dual Channel	
Sensor	CO₂ NDIR (non-dispersiv, infrared)	VOC VOC sensor (heated metal oxide semiconductor)
Display <i>(optional)</i>	LCD LCD 29x35 mm with RGB backlight	
Enclosure <i>(type-dependent)</i>	enclosure USE-M, PC, pure white, with removable cable entry	LCD cover PC, transparent
Protection	IP65 according to EN 60529	
Cable entry	M25, for wire max. Ø=7 mm, seal insert for fourfold cable entry	
Connection electrical	Mainboard removable plug-in terminal, max. 2,5 mm ²	Plug-in card removable plug-in terminal, max. 1,5 mm ²
Ambient condition	0..+50 °C, max. 85% rH short term condensation	
Notes	mixed gas sensors detect gases and vapours which can be oxidised (burnt): Body odours, tobacco smoke, exhalations emitted by materials (furniture, carpets, paint, glue ...)	

When several BUS devices are supplied by one 24 V AC voltage supply, it is to be ensured that all "positive" operating voltage input terminals (+) of the field devices are connected and all "negative" operating voltage input terminals (-) (=reference potential) are connected (in-phase connection of field devices). In the case of reversed polarity at one field device, a supply voltage short-circuit would be caused by that device.

The consequential short-circuit current flowing through this field may cause damage to it. Therefore, pay attention to correct wiring.

» MOUNTING ADVICES

In case of outdoor installation avoid direct rain and sun contact. Probably use sun respectively rain protection. Cable entry from bottom or side. For side cable routing set loop so that precipitation can drain defined. Observe permissible ambient condition.

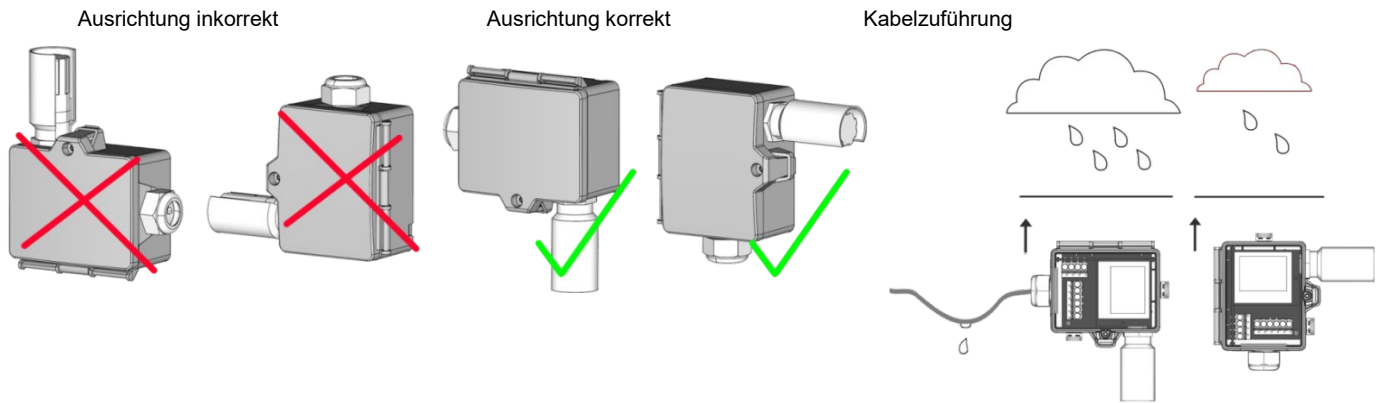

Regardless of the compass direction, the outdoor sensor should not be mounted in the following locations:

- on chimneys, under roofs, canopies or balconies
- in close proximity to an exhaust air opening
- above, below or next to windows and doors

» USE ENCLOSURE WITH UV AND WEATHER RESISTANCE

After some time, outdoor mounted plastics can lose their color and quality. Therefore, all USE housings are made of special white polycarbonate (PC). The light-stable colorants and additives are used to achieve optimum protection of the polymer while maintaining color stability. The titanium dioxide used is specially developed for polycarbonate and offers excellent UV protection through the reflection of the entire light spectrum including the UV component by 340 nm. This effectively counteracts the otherwise occurring photochemical polymer degradation. The colors stay full for a long time without fading. The material is also resistant to cold and frost.

» CONNECTION PLAN

To change the output voltage range (default: 0..10 V to 0..5 V) via jumper, the display must be removed from the board first.

LA+ CO2+VOC (Temp_rH) (LCD) RS485

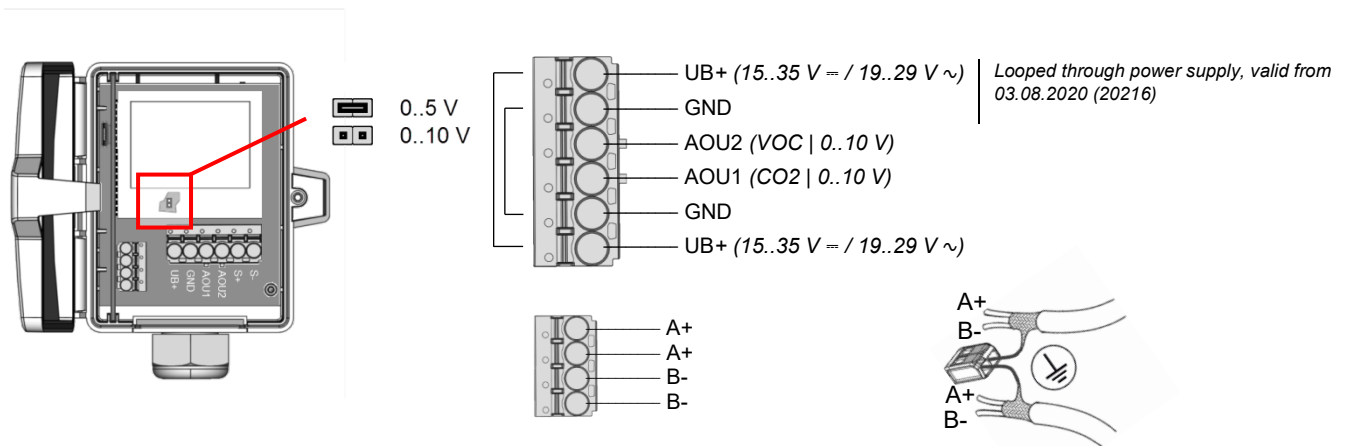

» **DIP SWITCH CONFIGURATION (PLUG-IN CARD)**

The BACnet address of the device is set binary coded in the range of 1 ... 127 via 7 dip-switches. (the address 0 is reserved and cannot be selected).

***factory default settings**

Termination 120 Ω
 Not active* | active

Baud
 9600* | 19200
 38400 | 76800

BACnet address
 ON=2⁰ (1)* | ON=2¹ (2) | ON=2² (4) | ON=2³ (8) | ON=2⁴ (16)
 ON=2⁵ (32) | ON=2⁶ (64)
 Address-Bsp.: 2+8+16+32+64=122

Object	Access	Description	COV Increment	Unit
AI-1	R	Relative Humidity	0..100 %	%rF
AI-5	R	CO2		ppm
AI-6	R	VOC		%
AI-7	R	CO2 VOC Mix		%

Object	Access	Description	Object AV-38 = 1 (Unit SI)		Object AV-38 = 2 (Unit Imperial)	
			COV increment / Unit		COV increment / Unit	
AI-0	R	Temperature	0..+250	°C	0..+480	°F
AI-2	R	Absolute humidity	0..80	g/m ³	0..35	gr/ft ³
AI-3	R	Relative humidity	0..85	KJ/kg	0..40	BTU/lb
AI-4	R	Dew point	0..80	°C	0..200	°F



BACnet Objects, PICS and BIBBs:
 USE-RS485 BACnet interface

A detailed description of the BACnet interface can be found at the following link: [Download](#)

» **APPLICATION NOTICE**



The Bluetooth dongle snaps into the socket easily. When removing, please fix the plug-in card (option PCB) so that it is not unintentionally pulled out.

» **CONFIGURATION**



The Thermokon bluetooth dongle with micro-USB (Item No.: 668262) is required for communication between USEapp and USE-M / USE L products. Commercial bluetooth dongles are not compatible.



Application-specific reconfiguration of the devices can be carried out using the Thermokon USEapp. The configuration is carried out in the voltage-supplied state.



The configuration-app and the app description can be found in the Google Play Store or in the Apple App Store.

» DIMENSIONS (MM)

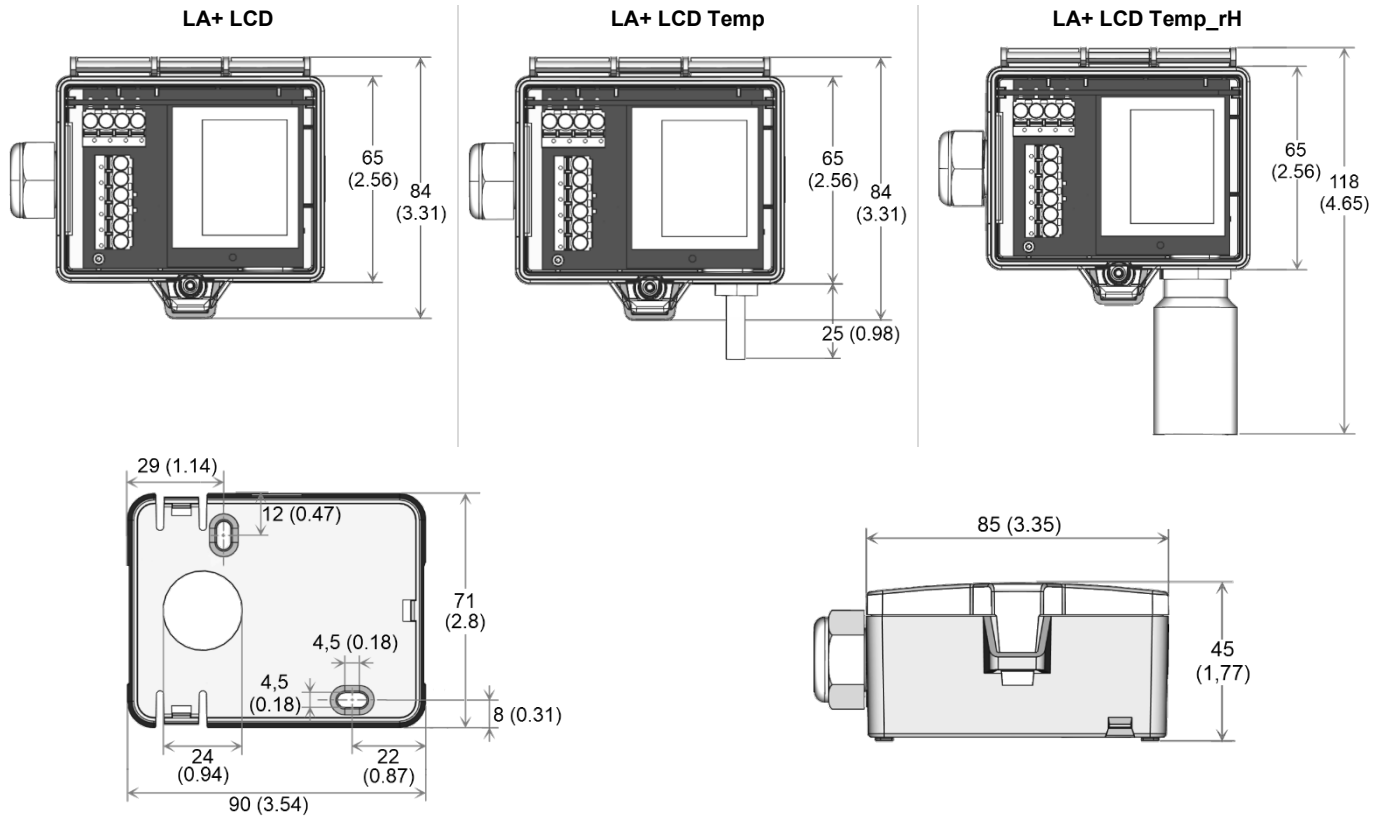

» ACCESSORIES (INCLUDED IN DELIVERY)

Mounting base

Item No. 631228

Mounting kit universal

Item No. 698511

• Cover screw + screw cover • 2 Rawlplugs • 2 Screws (countersunk head) • 2 Screws (rounded head)

» ACCESSORIES (OPTIONAL)

Bluetooth dongle

Item No. 668262

Filter stainless steel, wire mesh

Item No. 231169

RS485 Biasing Adapter

Item No. 811378